

BOILERMATE™ INDIRECT-FIRED WATER HEATERS



MODELS COVERED:

- WH-7 & 9 Classic Series
- Top Down™ TD Series
- RTR models
- WHS Premier Series

MODELS CODES:

- P: Packaged with circulator & Smart Control™
- L: Less Circulator, with Smart Control™
- Z: Dial Aquastat
- C: High-output commercial exchanger
- DW: Double-wall heat exchanger
- RTR: Pre-piped and wired

INSTALLER: LEAVE THIS MANUAL WITH THE OWNER

IMPORTANT GENERAL SAFETY INFORMATION - ADDITIONAL SPECIFIC SAFETY ALERTS APPEAR IN THE FOLLOWING INSTRUCTIONS.

⚠ WARNING READ CAREFULLY THE PRODUCT INSTALLATION, OPERATING AND MAINTENANCE MANUAL . FAILURE TO FOLLOW THE INSTRUCTIONS AND WARNINGS IN THE MANUAL MAY RESULT IN SERIOUS OR FATAL INJURY AND/OR PROPERTY DAMAGE, AND WILL VOID THE PRODUCT WARRANTY. THIS PRODUCT MUST BE INSTALLED BY A QUALIFIED PROFESSIONAL. FOLLOW ALL APPLICABLE LOCAL AND STATE CODES AND REGULATIONS, IN THE ABSENCE OF SUCH CODES, FOLLOW THE CURRENT EDITIONS OF THE NATIONAL PLUMBING CODE AND NATIONAL ELECTRIC CODE, AS APPLICABLE.



THIS IS THE SAFETY ALERT SYMBOL. IT IS USED TO ALERT YOU TO POTENTIAL PERSONAL INJURY AND OTHER HAZARDS. OBEY ALL SAFETY MESSAGES THAT FOLLOW THIS SYMBOL TO REDUCE THE RISK OF PERSONAL INJURY AS WELL AS PROPERTY DAMAGE.



The heat transfer medium must be water or other nontoxic fluid having a toxicity rating or class of 1, as listed in Clinical Toxicology of Commercial Products, 5th edition. The pressure of the heat transfer medium must be limited to 30 PSIG by an approved safety or relief valve.

1. TABLE OF CONTENTS

2. Pre-Installation Checklist.....	2	9. Wiring All Dial Control Models (Except RTR Models).....	19
3. Required Components and Accessories Checklist.....	3	10. Wiring All Ready-To-Run (RTR) Models.....	22
4. WH-7 & 9 Classic Series Piping Installation.....	4	11. Startup Procedure For All Models.....	24
5. Top Down™ TD-Series Piping Installation.....	6	12. Setting the Smart Control™.....	25
6. Ready-To-Run RTR-Series Piping Installation.....	8	13. Troubleshooting.....	26
7. WHS Premier Series Piping Installation.....	10	14. Replacement Parts.....	27
8. Wiring All Smart Control™ Models.....	12	15. General Safety Information.....	28

2. PRE-INSTALLATION CHECKLIST

IMPORTANT STEPS AND DECISIONS REQUIRED BEFORE INSTALLATION

- THIS PRODUCT MUST BE INSTALLED AND MAINTAINED BY A LICENSED PROFESSIONAL. IN ADDITION TO THE INSTRUCTIONS IN THIS MANUAL, FOLLOW ALL APPLICABLE LOCAL AND STATE CODES OR IN THE ABSENCE OF SUCH CODES, THE CURRENT EDITIONS OF THE NATIONAL PLUMBING CODE AND THE NATIONAL ELECTRIC CODE.**
- DRIP PAN AND DRAIN:** This appliance should not be installed in an area where leakage of the tank or connections can result in damage to the area adjacent to the appliance or to lower floors of the structure. When such locations cannot be avoided, a suitable drain pan, adequately drained and kept clear, must be installed under the appliance.
- CAUTION:** Determine whether your water is corrosive or acidic, and that there are no suspended solids, toxic or other substances or abnormally high chlorine levels in the water that could damage or affect the BOILERMATE™ or the rest of your plumbing system.

BOILERMATE™ may not be supplied with enough hot boiler water to "recover" adequately. The delivery of domestic hot water will be diminished. In many, but not all cases, this is not a problem because the routine oversizing of boiler output is adequate for both loads.

- 2. Priority System** - Under this wiring option the BOILERMATE™ will be supplied before space heating.

⚠ WARNING In limited circumstances, space heating can be lost in the home in this priority mode. Any demand for space heating is postponed until the BOILERMATE™ has reached its set temperature. This delay in supplying the space heating zones is usually not noticed by the inhabitants of the living spaces. However, in the event of certain malfunctions such as circulator or thermostat failure, space heating could be delayed indefinitely. If undetected and uncorrected, freezing damage to piping could result.

⚠ WARNING USE GLYCOL ONLY WITH DOUBLE-WALLED HEAT EXCHANGER MODELS. Glycol is a hazardous substance. To avoid seepage or leakage of glycol to surfaces where humans or animals can ingest it, use glycol only in double-walled units, so that any leaks will most likely be released to the atmosphere. However, a leak to a surface area may still occur, so any use of glycol must be monitored closely and humans and animals should be protected from contact with the unit.

⚠ WARNING Do not connect the BOILERMATE™ domestic supply with baseboard or other space heating units or elements. Any contaminants in the baseboard units will contaminate the potable water in the BOILERMATE™ and also adversely affect its performance.

- Wiring Options. Select either a Non-Priority or Priority System:**
Two options are available when wiring the controls of the BOILERMATE™ in the space heating system (boiler and distribution elements).
 - 1. Non-Priority System** - The controls of the BOILERMATE™ must be wired as a separate heating zone with a standard zone valve or a separate circulator dedicated to the BOILERMATE™ "zone".

- Select Circulator versus Zone Valve**
The flow of hot boiler water to the BOILERMATE™ can be controlled with either a motorized zone valve or a circulator.
 - 1. Separate circulator.** The recommended way to provide adequate flow through the BOILERMATE™ heat exchanger is to use a separate dedicated circulator with a minimum flow rate of 5 gpm. This option may be used even though the heating system utilizes zone valves.
 - 2. Zone valve** (system flow of 4-8 gpm). If a zone valve is to be used, a minimum flow rate of 5 gpm with all zones in use is required. A full-port zone valve should be used.
- All installations require a low-water cut-off or automatic fill valve on your boiler system to reduce the risk of boiler water loss.
- Steam boiler installations require a low-water cut-off which is also required by most codes.
- Installation of a vacuum breaker is required to prevent damage to the BOILERMATE™ when drained. There must be no valves installed between the vacuum breaker and BOILERMATE™.

NOTICE: In this non-priority option, the BOILERMATE™ will be supplied just as another zone. This means that if all space heating zones call for hot boiler water at the same time, the

3. REQUIRED COMPONENTS AND ACCESSORIES CHECKLIST

MODEL	CIRCULATOR	ZONE VALVE*	SHUTOFF VALVE	VACUUM BREAKER	RELIEF VALVE	THERMAL EXPANSION TANK	DRAIN
WH SERIES	Residential = 5GPM Commercial = 10GPM Except "P" Models	*If Circulator not used 3/4" Full Port or 1" STD	4	1	Included	Required (See Therm-X-Trol® Sizing Guide)	Included
TD SERIES	5GPM Except "P" Models	*If Circulator not used 3/4" Full Port or 1" STD	4	1	Included	Required (See Therm-X-Trol® Sizing Guide)	Included
RTR SERIES	Included	N/A	4	1	Included	Required (See Therm-X-Trol® Sizing Guide)	Included
WHS SERIES	Residential = 5GPM Commercial = 10GPM Except "P" Models	*If Circulator not used 3/4" Full Port or 1" STD	4	1	Included	Required (See Therm-X-Trol® Sizing Guide)	Included

ALL INSTALLATIONS REQUIRE TEFLON SEALING TAPE OR PIPE DOPE FOR THREADED JOINTS.
SEE HEAT EXCHANGER PRESSURE DROP CHART TO DETERMINE PUMP HEAD REQUIREMENTS.

Use this chart to select the proper circulator for your BOILERMATE™.

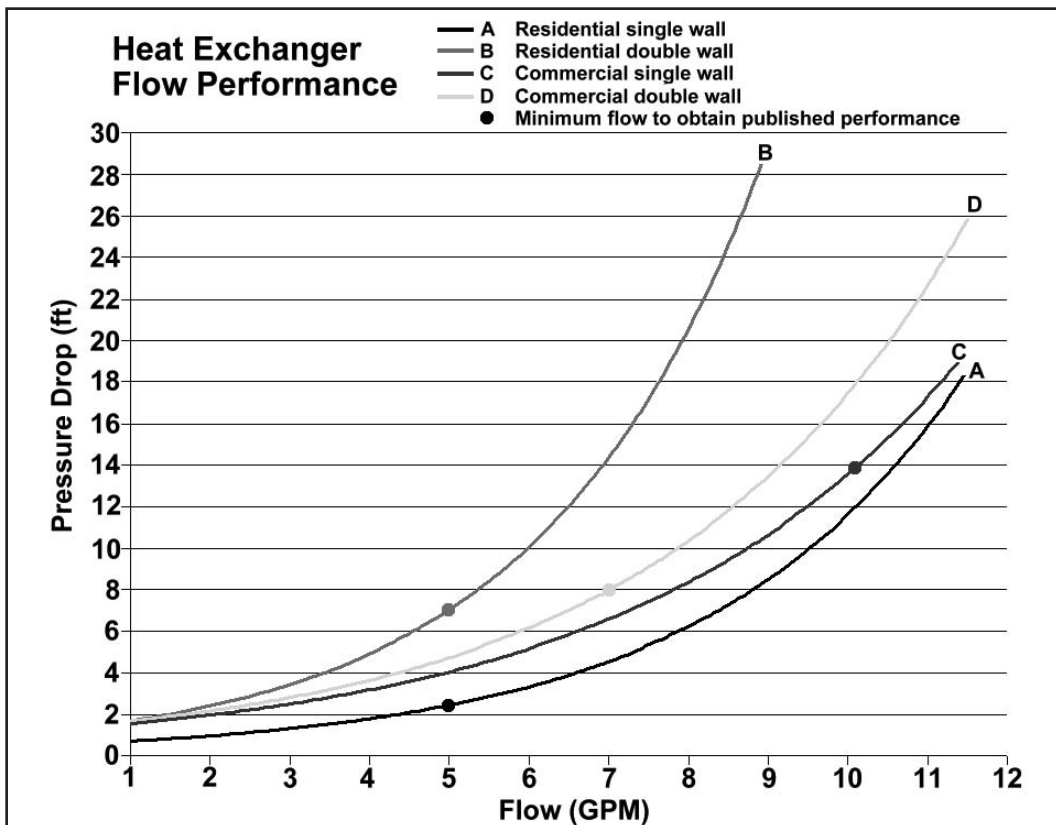

CAUTION If a steel hydropneumatic tank is in place, AMTROL® recommends replacing it with a properly sized EXTROL® or Radiant EXTROL™ expansion tank. Otherwise, significant heat transfer problems can occur by causing air to be trapped in the heat exchanger. If the boiler system has an EXTROL® or Radiant EXTROL™ expansion tank and the boiler temperatures are being changed, resize the EXTROL® or Radiant EXTROL™ expansion tank.

4. WH-7 & 9 CLASSIC SERIES PIPING INSTALLATION

DOMESTIC WATER PIPING

1. Thread the included 3/4" brass tee onto the pipe marked COLD WATER.
2. Screw the 3/4" drain valve into the opposite end of the brass tee.
3. Connect the cold water supply to the remaining port on the brass tee.
4. Temporarily attach the top tee fitting (with o-ring face seal) to the union nut on top of the tank. Test fit the piping near the tee before soldering. Remove the tee before soldering connections to avoid damage to the top o-ring seal or plastic liner.

Note: Do not solder piping within 24 inches of the top tee fitting while attached to the tank.

5. Make an 8-inch "heat trap" as shown in the diagram. This will reduce standby losses from heat migrating up the piping. Continue this line to the domestic hot water system.
6. Install the included T&P relief valve on the top port of the top tee connection. Plumb a blowdown tube to within 6 inches of a floor drain or as directed by plumbing code.
7. When all domestic water piping is complete, open the cold water supply and allow some water to enter the tank. Look and listen for signs of leaks and repair as necessary before continuing.

Note: If installing on a city supply, ensure a dedicated Thermal Expansion tank (Therm-X-Trol® or equivalent) is used.

BOILER PIPING

1. Plumb the circulator or zone valve on the BOILER SUPPLY line. If using a separate circulator, the pump flange can be mounted directly to the threaded pipe marked BOILER SUPPLY. Alternately, the circulator can be placed anywhere on the boiler supply line.

2. Pipe the BOILER RETURN connection to the boiler return line.

CAUTION Be sure the return line is NOT plumbed to the suction side of any heating circulators. This may require moving the heating circulator off the boiler tapping on packaged boilers. Failure to do so will result in overheating and tank damage when the heating system is in operation.

3. Install a weighted flow check on the boiler return line. This is not necessary on systems utilizing a zone valve to control the BoilerMate™ temperature.

4. After completing the boiler piping, slowly open the boiler fill valve and pressurize the BoilerMate™ loop. Check for leaks and repair as necessary. Proceed to the appropriate wiring section in this manual.

WARNING If installing on city water supply a properly sized THERM-X-TROL® is required with the BoilerMate™ and should be installed as set forth in the THERM-X-TROL® product installation manual.

Clearance From Combustible Surfaces

LEFT SIDE	1"	REAR	1"
RIGHT SIDE	1"	FLOOR	0"
TOP	9"	FRONT	1"

Recommended Clearance for Servicing

LEFT	12"	HEAD ROOM	9"
RIGHT	12"	REAR	1"
FRONT	30"		

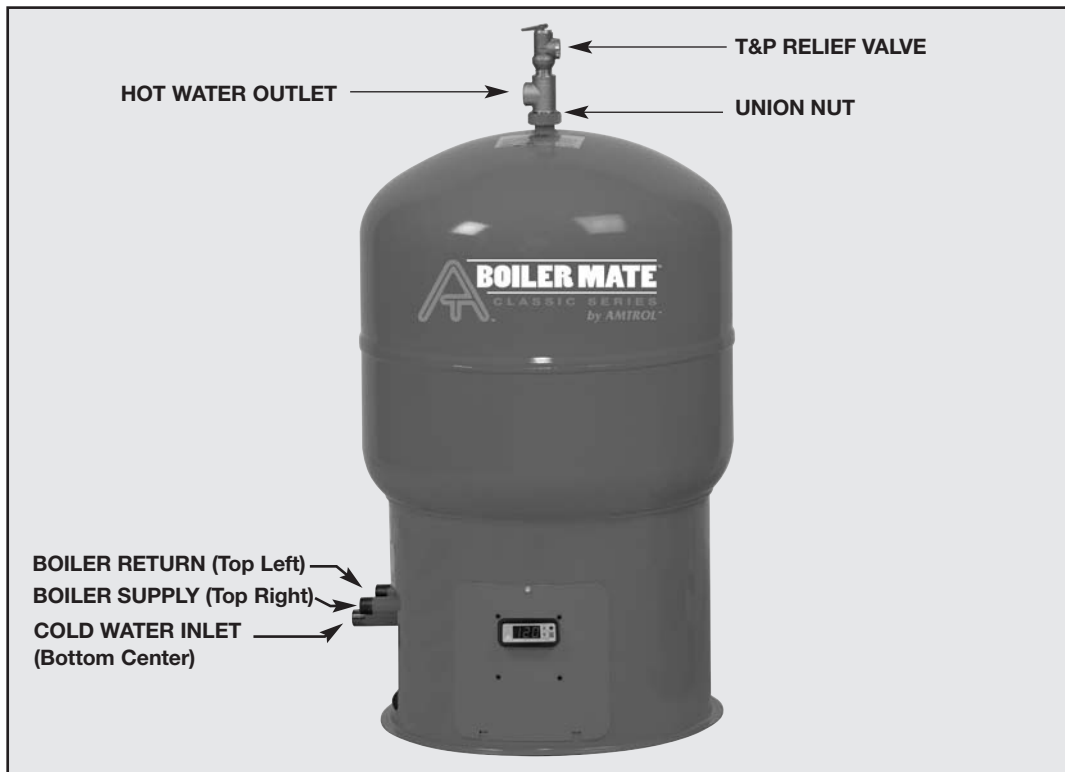

PIPING USING SEPARATE CIRCULATOR PUMP (RECOMMENDED)

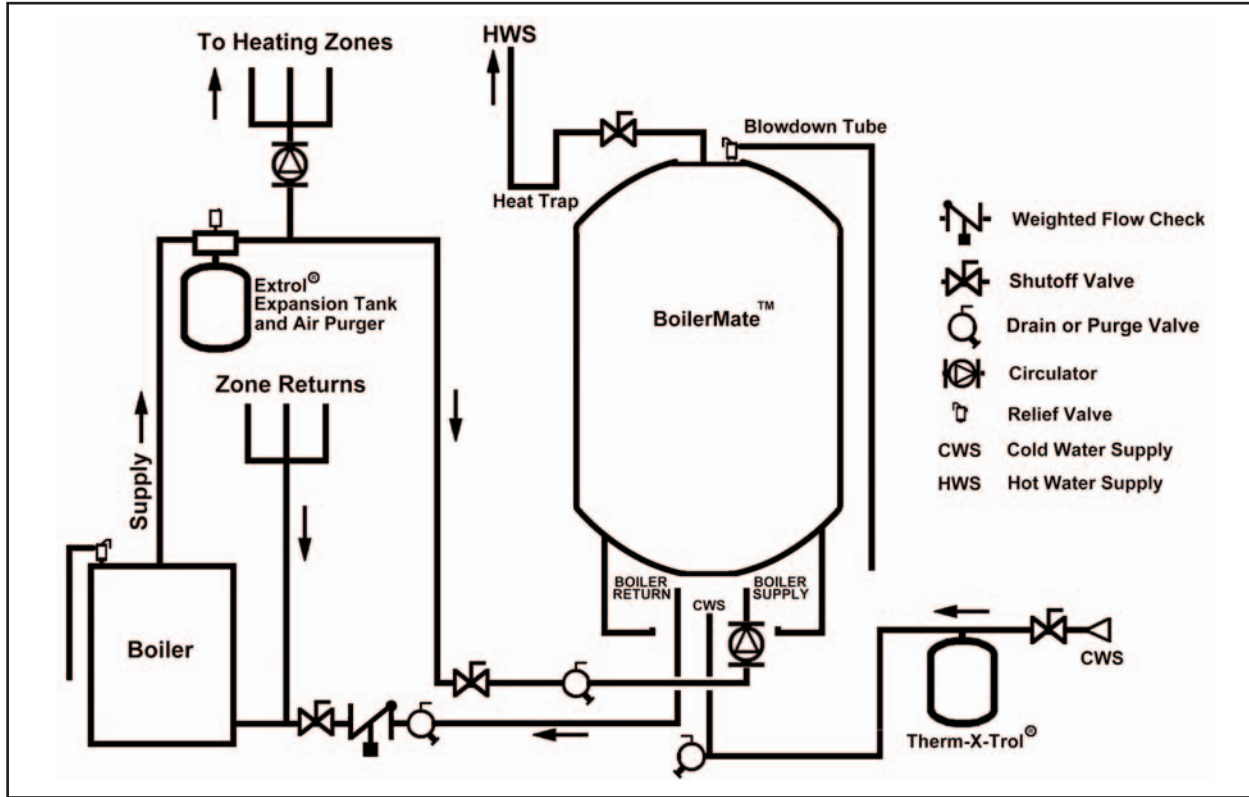

PIPING USING ZONE VALVE WITH EXISTING HEATING SYSTEM CIRCULATOR

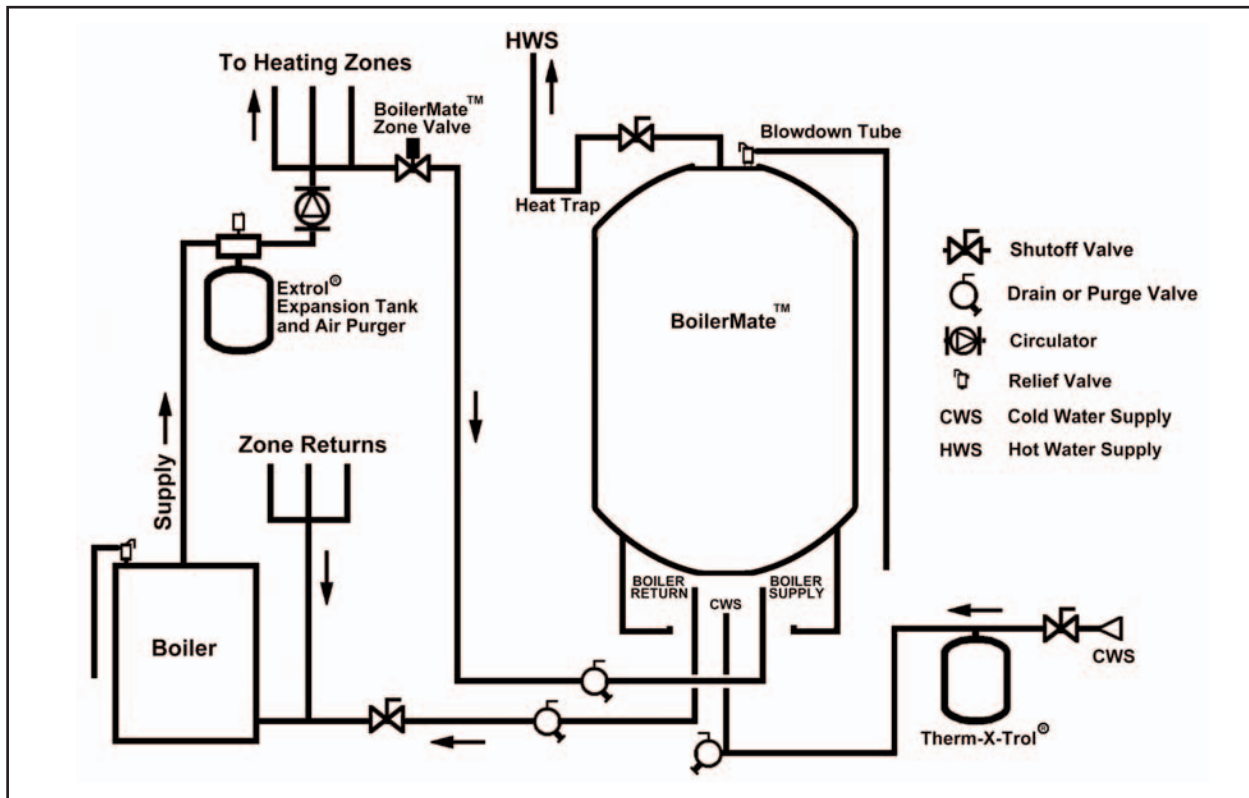

5. TOP DOWN™ TD-SERIES PIPING INSTALLATION

DOMESTIC WATER PIPING

1. Connect the cold water supply to the pipe labeled COLD WATER
2. Connect the HOT WATER piping to the domestic hot water system.
3. Make an 8-inch "heat trap" on the HOT WATER outlet as shown in the diagram. This will reduce standby losses from heat migrating up the piping.
4. When all domestic water piping is complete, open the cold water supply and allow some water to enter the tank. Look and listen for signs of leaks and repair as necessary before continuing.

Note: If installing on a city supply, ensure a dedicated Thermal Expansion tank (Therm-X-Trol® or equivalent) is used.

5. Install a blowdown tube on the T&P relief valve outlet. Plumb to within 6 inches above a floor drain or as directed by plumbing code.

Clearance From Combustible Surfaces

LEFT SIDE1"	REAR1"
RIGHT SIDE1"	FLOOR0"
TOP9"	FRONT1"

BOILER PIPING

1. Plumb the circulator or zone valve on the BOILER SUPPLY line. If using a separate circulator, the pump flange can be mounted directly to the threaded pipe marked BOILER SUPPLY. Alternately, the circulator can be placed anywhere on the boiler supply line.
2. Pipe the BOILER RETURN connection to the boiler return line.

CAUTION Be sure the return line is **NOT** plumbed to the suction side of any heating circulators. This may require moving the heating circulator off the boiler tapping on packaged boilers. Failure to do so will result in overheating and tank damage when the heating system is in operation.

3. Install a weighted flow check on the boiler return line. This is not necessary on systems utilizing a zone valve to control the BoilerMate™ temperature.
4. After completing the boiler piping, slowly open the boiler fill valve and pressurize the BoilerMate™ loop. Check for leaks and repair as necessary. Proceed to the appropriate wiring section in this manual.

Recommended Clearance for Servicing

LEFT	12"	HEAD ROOM	9"
RIGHT	12"	REAR	1"
FRONT	30"		

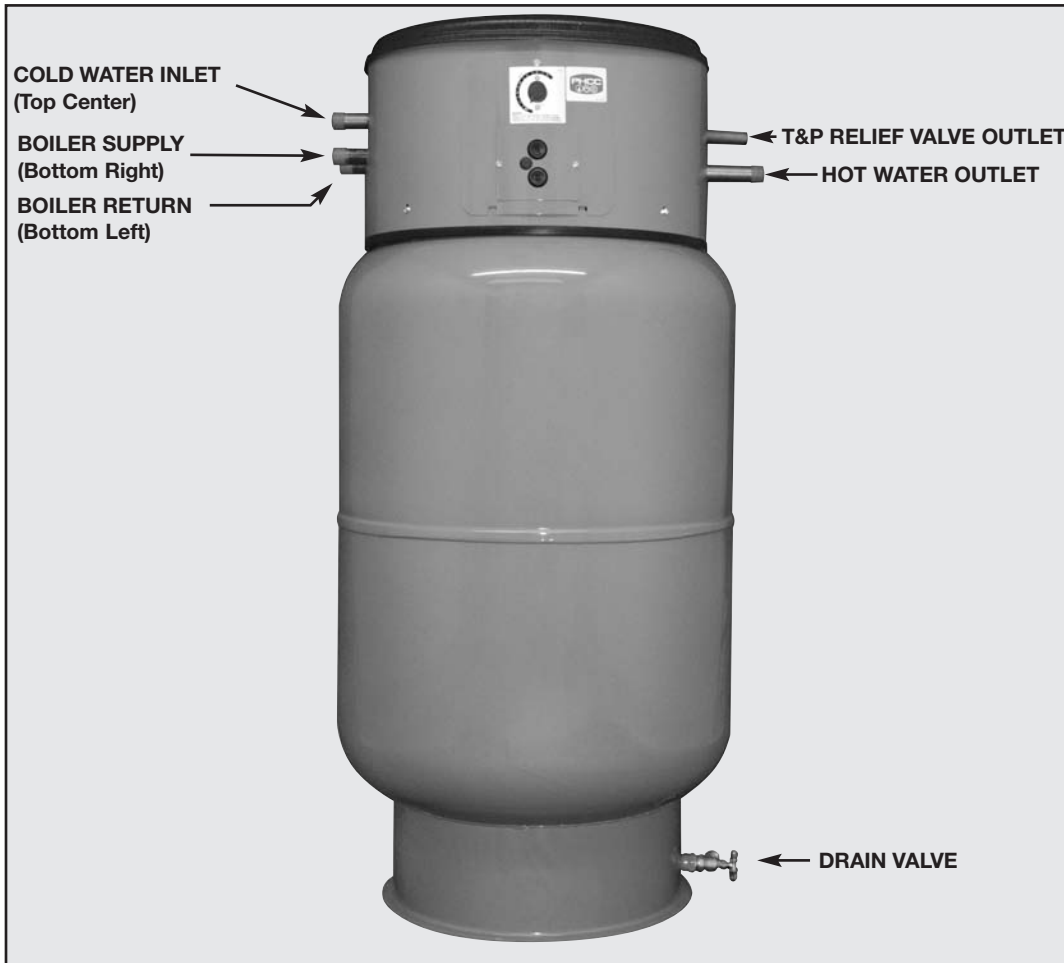

PIPING USING SEPARATE CIRCULATOR PUMP (RECOMMENDED)

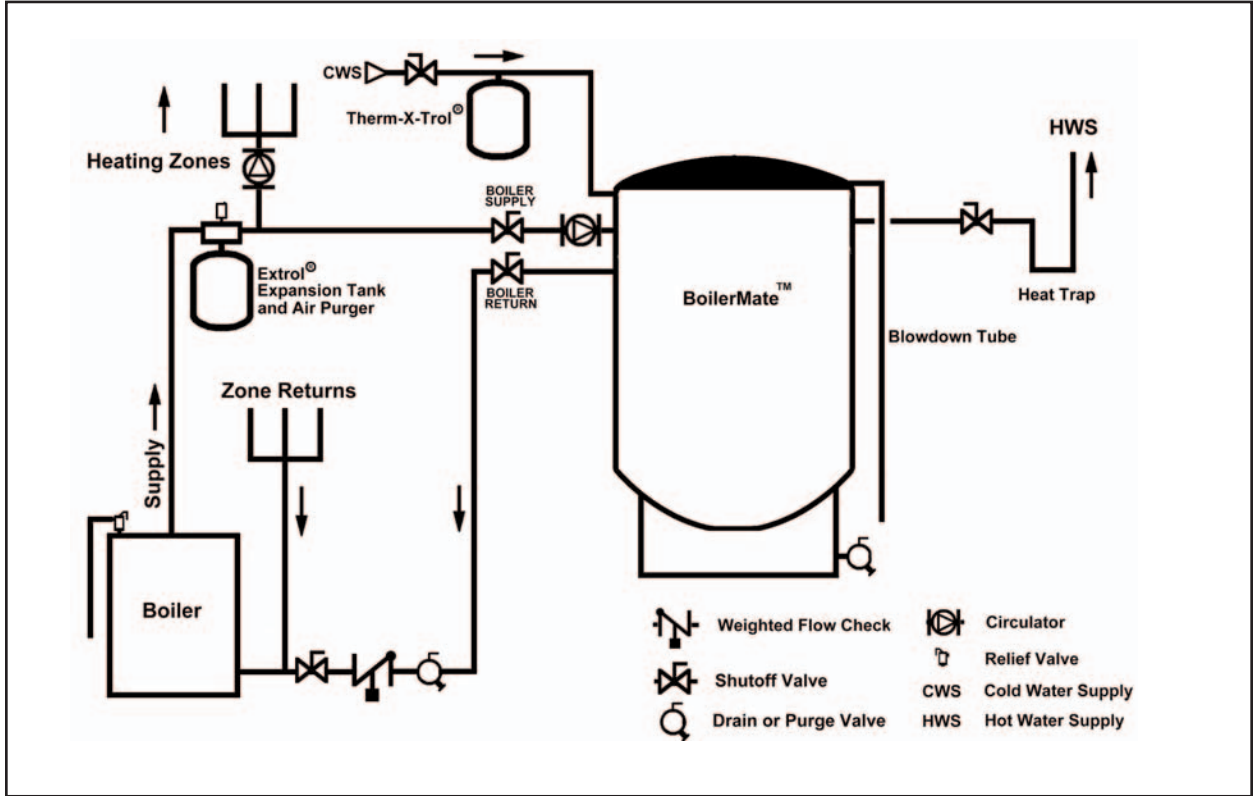

PIPING USING ZONE VALVE WITH EXISTING HEATING SYSTEM CIRCULATOR

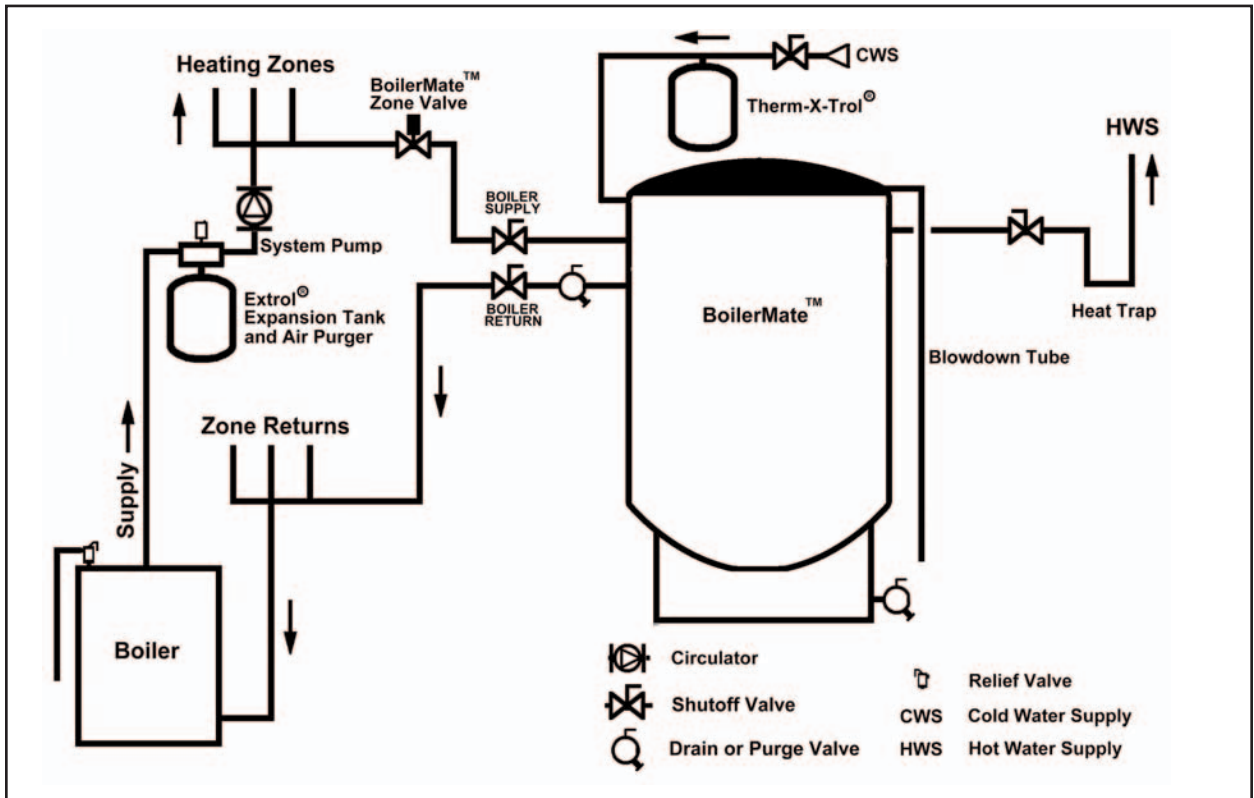

6. READY-TO-RUN RTR-SERIES PIPING INSTALLATION

DOMESTIC WATER PIPING

1. Connect the cold water supply to the pipe labeled COLD WATER.
2. Connect the HOT WATER piping to the domestic hot water system.
3. Make an 8-inch "heat trap" on the HOT WATER outlet as shown in the diagram. This will reduce standby losses from heat migrating up the piping.
4. When all domestic water piping is complete, open the cold water supply and allow some water to enter the tank. Look and listen for signs of leaks and repair as necessary before continuing.

Note: If installing on a city supply, ensure a dedicated Thermal Expansion tank (Therm-X-Trol® or equivalent) is used.

5. Install a blowdown tube on the T&P relief valve outlet. Plumb to within 6 inches above a floor drain or as directed by plumbing code.



SIDE VIEW

BOILER PIPING

1. Plumb the BOILER SUPPLY line. The circulator and flow check are factory installed
2. Pipe the BOILER RETURN connection to the boiler return line.

CAUTION Be sure the return line is NOT plumbed to the suction side of any heating circulators. This may require moving the heating circulator off the boiler tapping on packaged boilers. Failure to do so will result in overheating and tank damage when the heating system is in operation.

3. After completing the boiler piping, slowly open the boiler fill valve and pressurize the heat exchanger loop. Check for leaks and repair as necessary. Proceed to the appropriate wiring section in this manual.

Clearance From Combustible Surfaces

LEFT SIDE	.1"	REAR	.1"
RIGHT SIDE	.1"	FLOOR	.0"
TOP	.9"	FRONT	.1"

Recommended Clearance for Servicing

LEFT	12"	HEAD ROOM	36"
RIGHT	12"	REAR	1"
FRONT	30"		

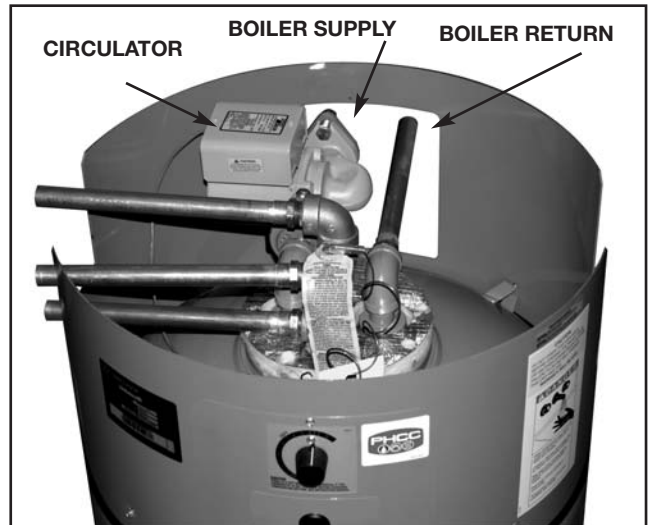

TOP VIEW

PIPING MODELS WITH PRE-INSTALLED CIRCULATOR W/INTEGRAL FLOW CHECK

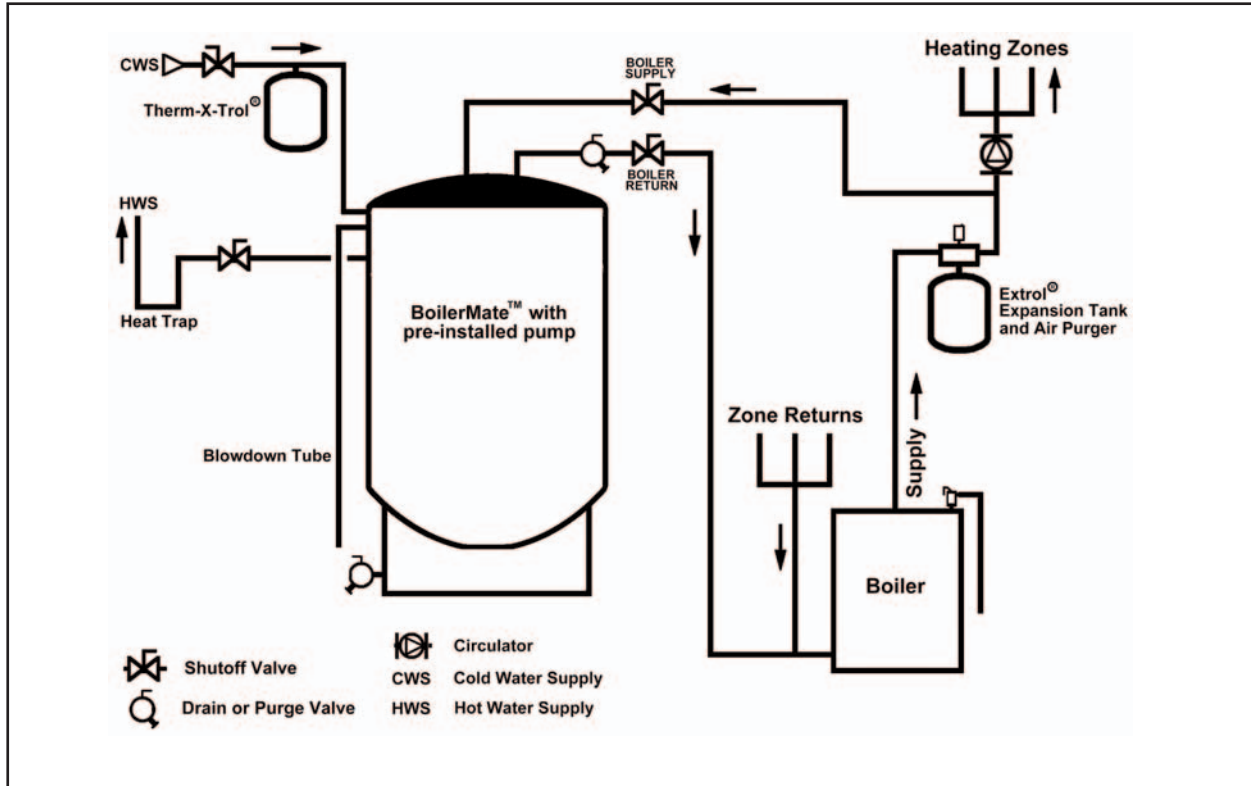

7. WHS PREMIER SERIES PIPING INSTALLATION

DOMESTIC WATER PIPING

1. Thread the included brass tee onto the pipe marked COLD WATER.
2. Screw the drain valve into the opposite end of the brass tee
3. Connect the cold water supply to the remaining port on the brass tee
4. Thread the included T&P Safety Relief Valve into the offset 3/4" port on the top plate. Install a blowdown tube to within 6 inches of a floor drain or as directed by plumbing code.
5. Connect the center hot water outlet port on the top plate to the domestic hot water system.
6. Make an 8-inch "heat trap" as shown in the diagram. This will reduce standby losses from heat migrating up the piping.
7. When all domestic water piping is complete, open the cold water supply and allow some water to enter the tank. Look and listen for signs of leaks and repair as necessary before continuing.

Note: If installing on a city supply, ensure a dedicated Thermal Expansion tank (Therm-X-Trol® or equivalent) is used.

Clearance From Combustible Surfaces

LEFT SIDE	1"	REAR	1"
RIGHT SIDE	1"	FLOOR	0"
TOP	.9"	FRONT	1"

BOILER PIPING

1. Plumb the circulator or zone valve on the BOILER SUPPLY line. If using a separate circulator, the pump flange can be mounted directly to the threaded pipe marked BOILER SUPPLY. Alternately, the circulator can be placed anywhere on the boiler supply line.
2. Pipe the BOILER RETURN connection to the boiler return line.

CAUTION Be sure the return line is **NOT** plumbed to the suction side of any heating circulators. This may require moving the heating circulator off the boiler tapping on packaged boilers. Failure to do so will result in overheating and tank damage when the heating system is in operation.

3. Install a weighted flow check on the boiler return line. This is not necessary on systems utilizing a zone valve to control the BoilerMate™ temperature.
4. After completing the boiler piping, slowly open the boiler fill valve and pressurize the BoilerMate™ loop. Check for leaks and repair as necessary. Proceed to the appropriate wiring section in this manual.

Recommended Clearance for Servicing

LEFT	12"	HEAD ROOM	36"
RIGHT	12"	REAR	1"
FRONT	30"		

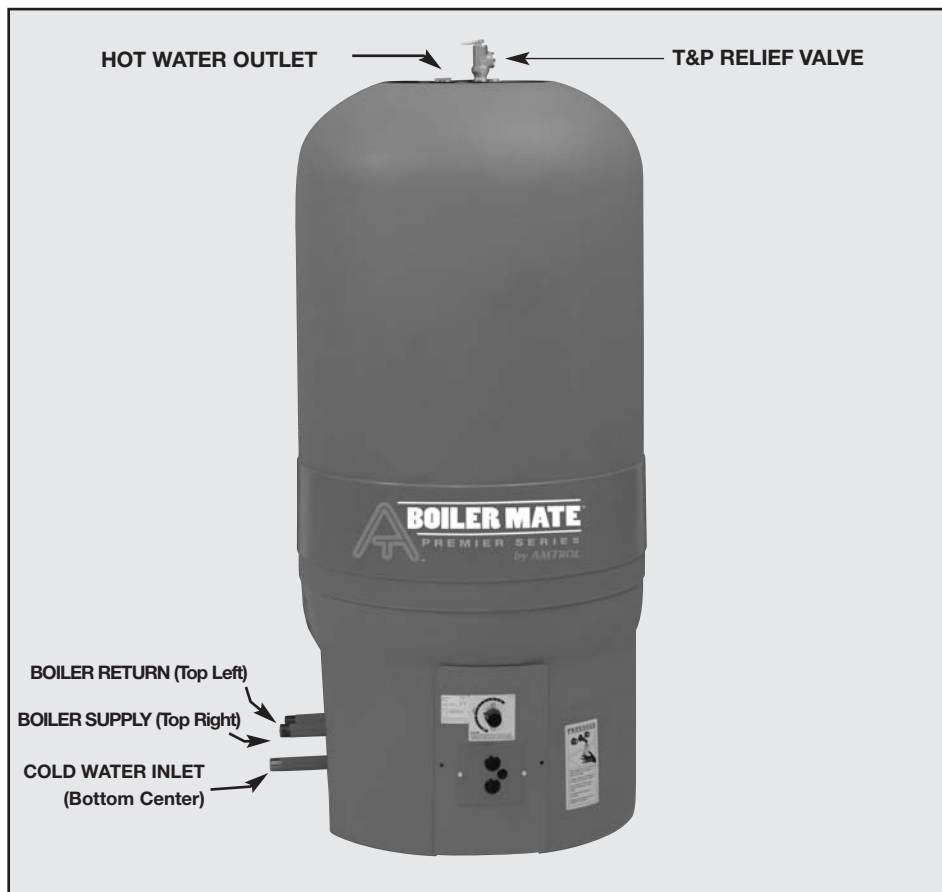

PIPING USING SEPARATE CIRCULATOR PUMP (RECOMMENDED)

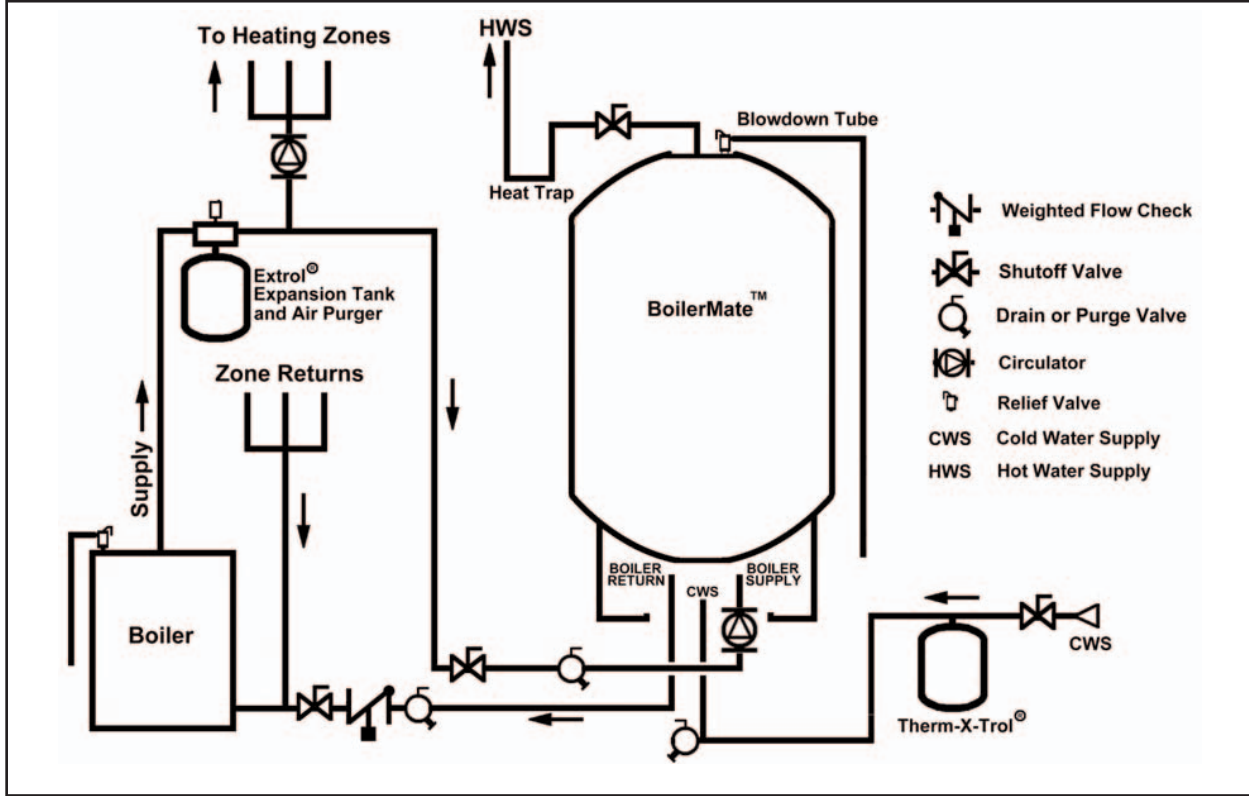

PIPING USING ZONE VALVE WITH EXISTING HEATING SYSTEM CIRCULATOR

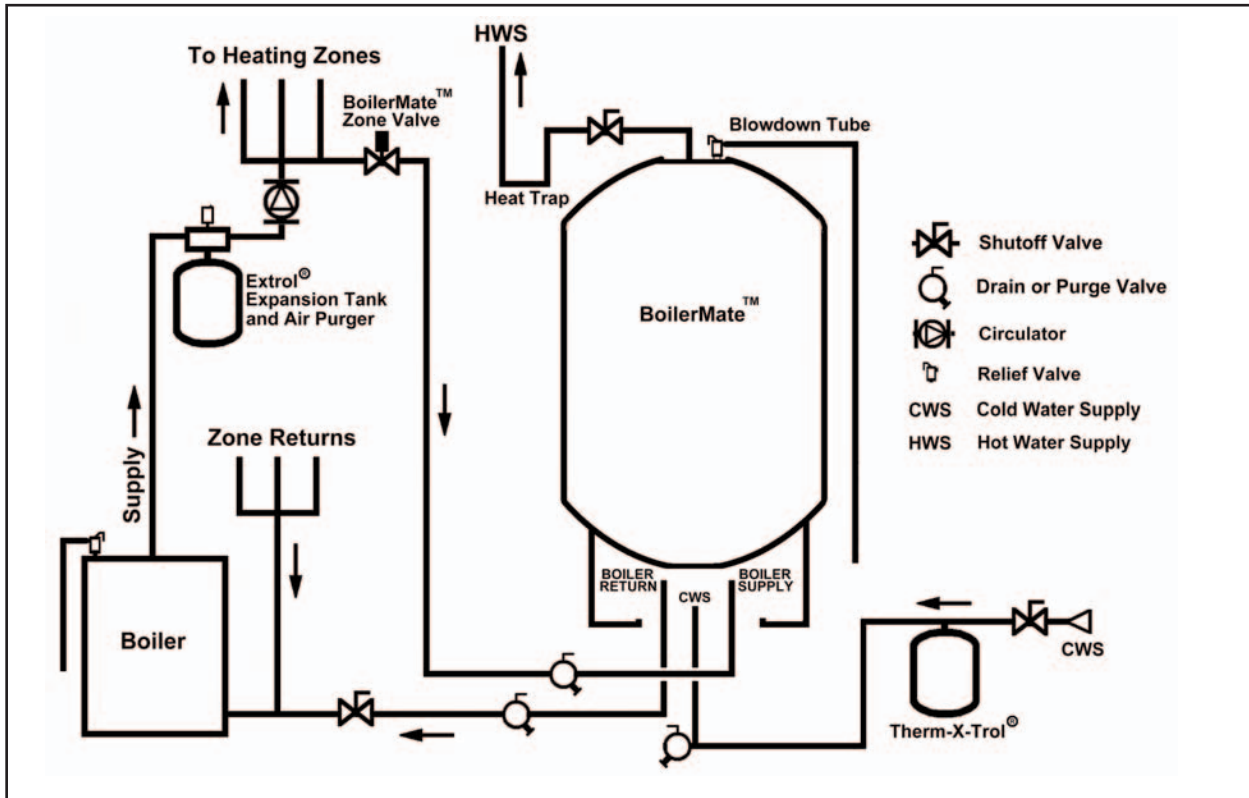

8. WIRING ALL SMART CONTROL™ MODELS

The Smart Control™ incorporates all the switching and temperature control functions necessary to control the BoilerMate™. The diagram below shows internal wiring and the associated functions.

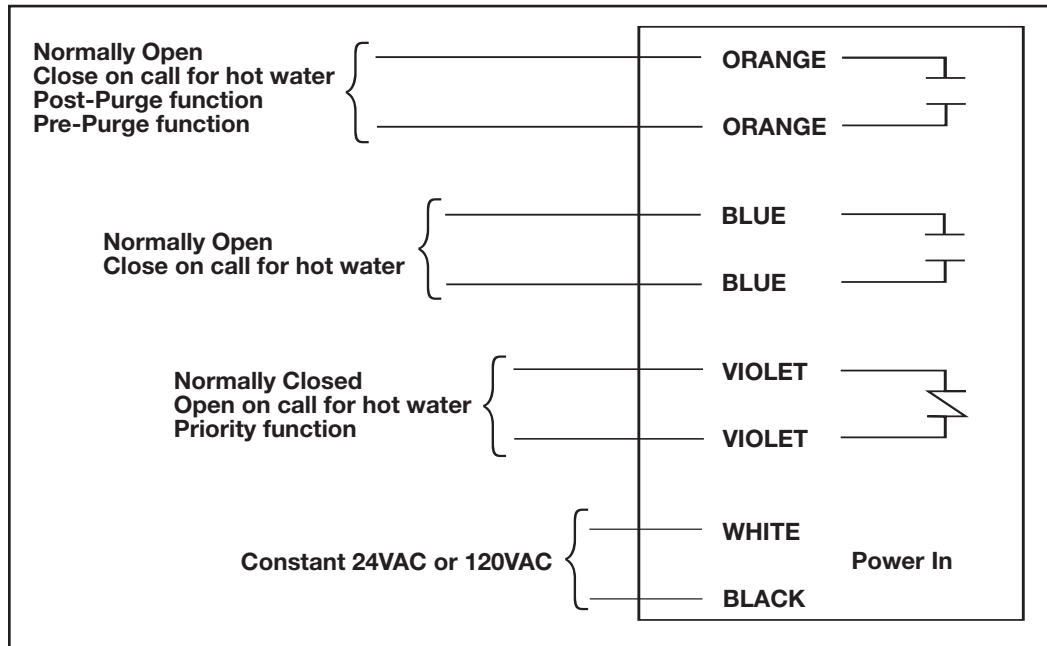

After wiring is complete, insert the white thermistor (sensor) plug into the receptacle at the base of the Smart Control™. Select the plug marked CIRCULATOR or ZONE VALVE based on the application. Zone valves can be slow actuating. Therefore, the zone valve sensor contains a built-in temperature offset to account for the time it takes the zone valve to fully close. This results in potable water temperature that is representative of the Smart Control™ temperature set point. This is why it is important to install the correct sensor into the Smart Control™. See Page 2 for information regarding the selection of a circulator or zone valve.

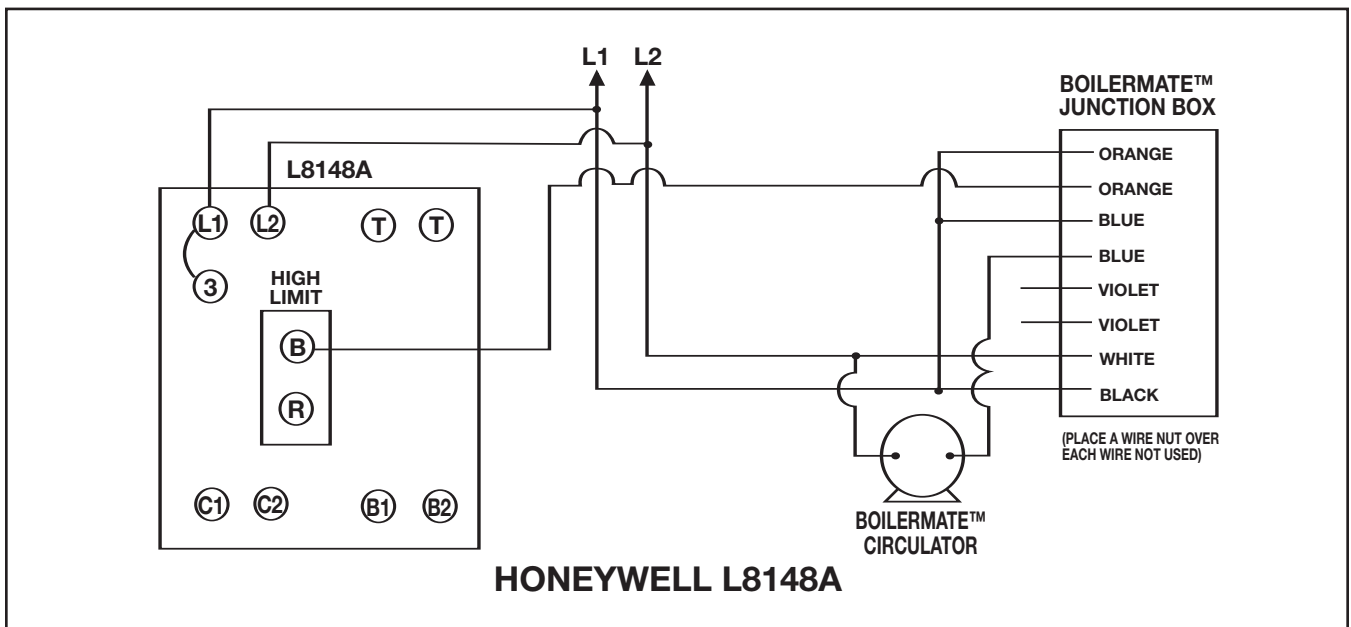
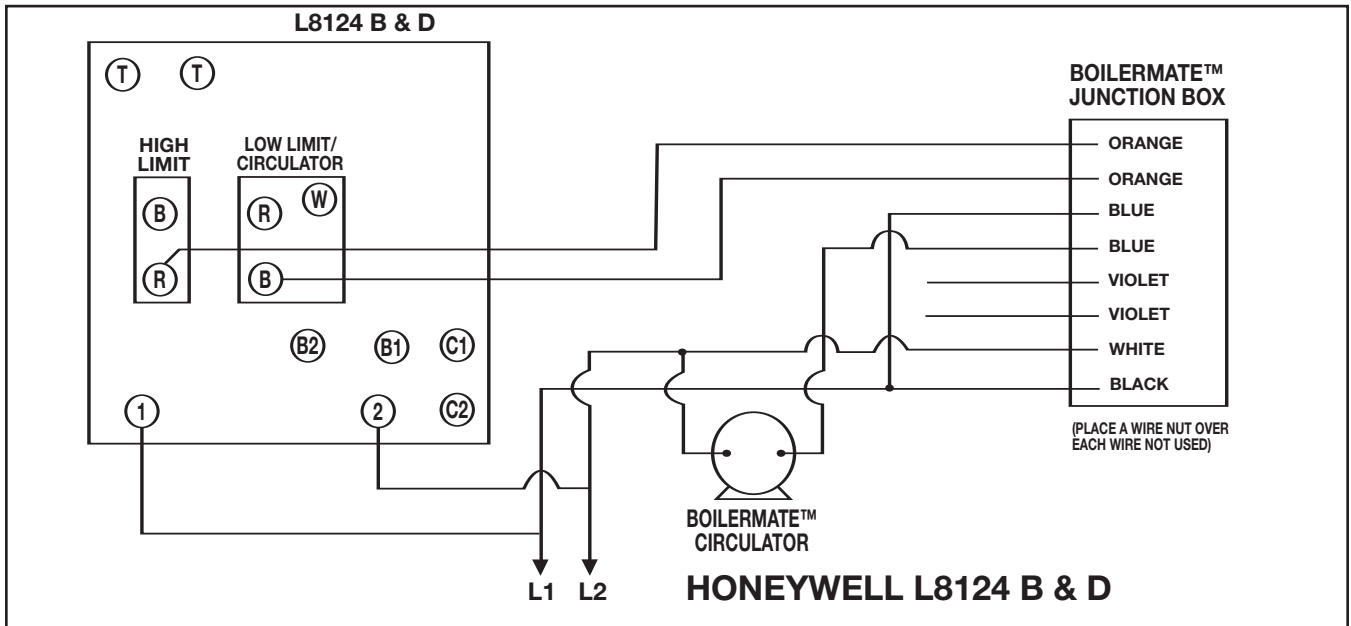
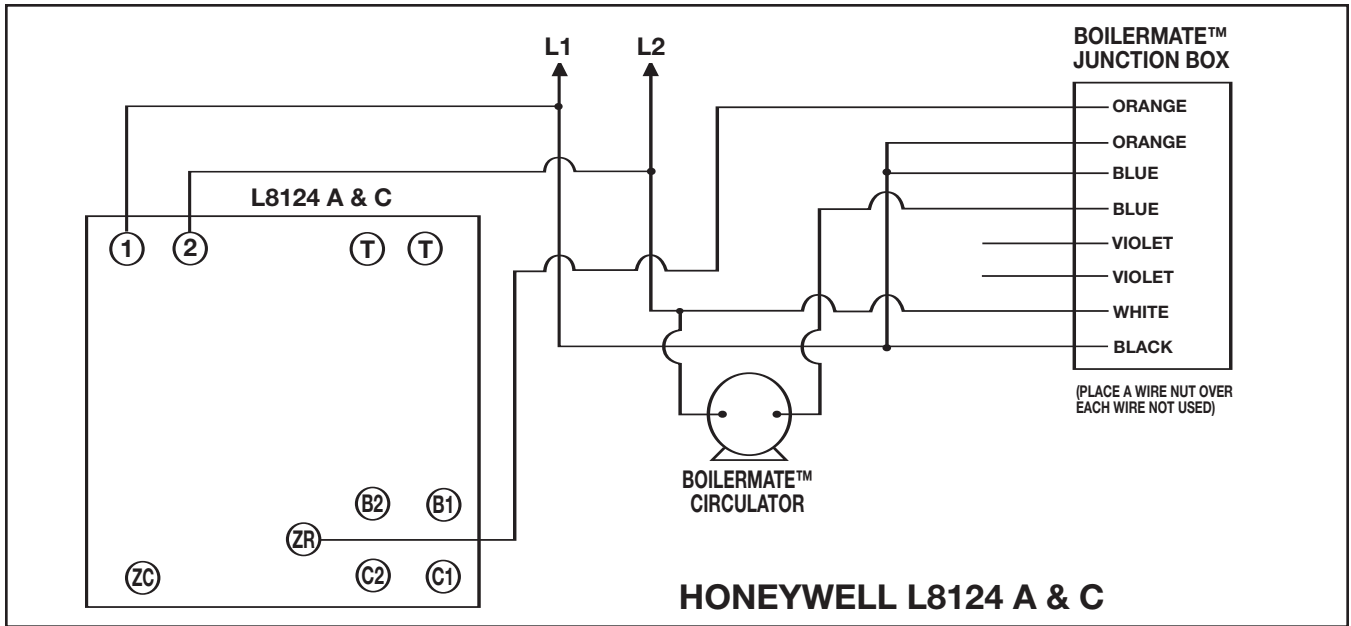

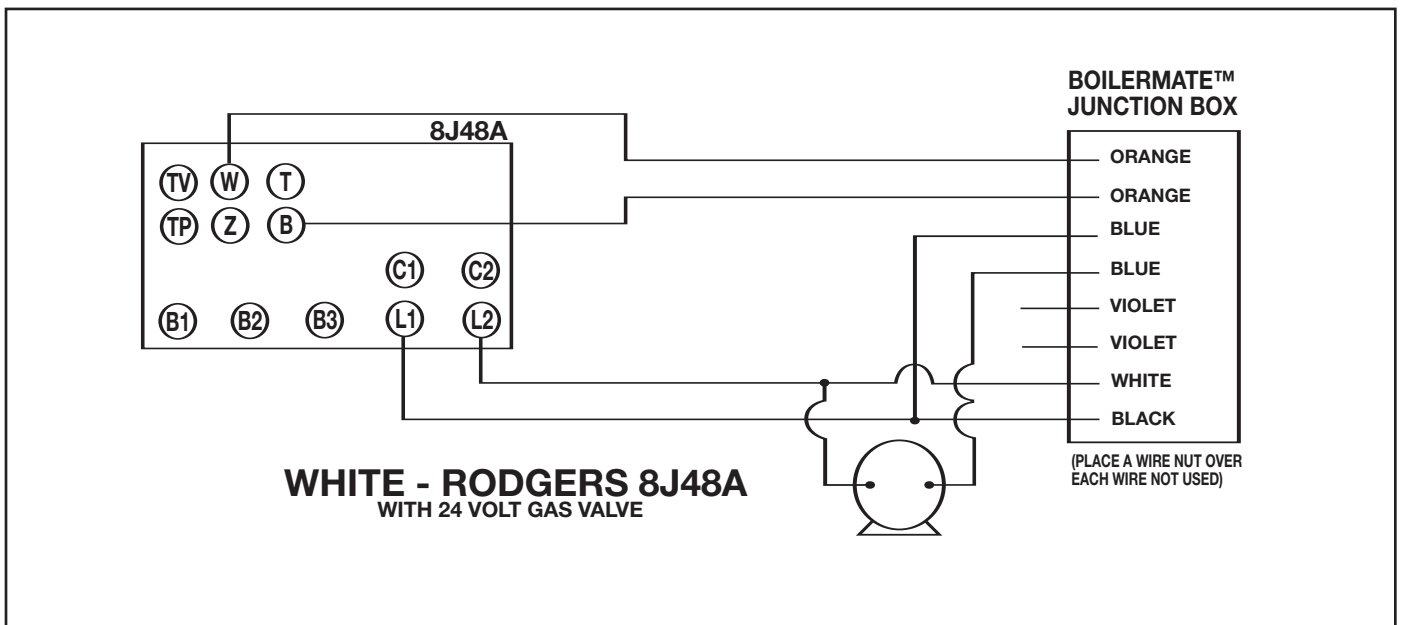
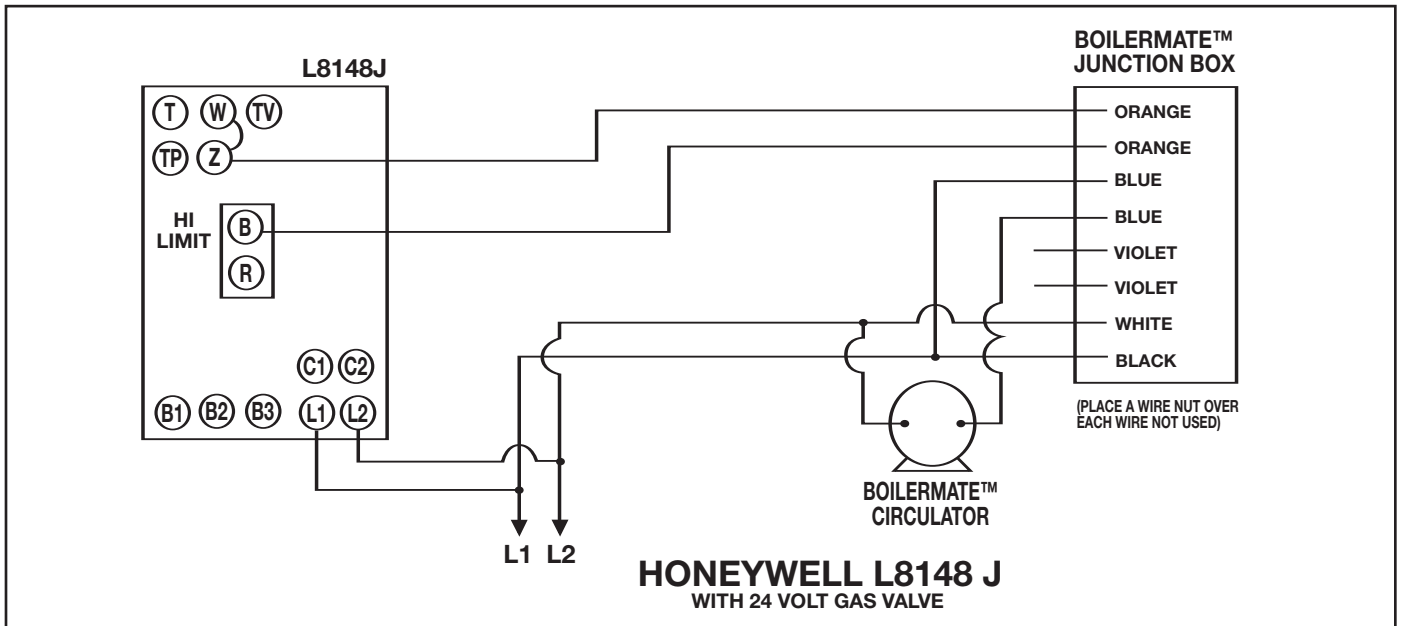
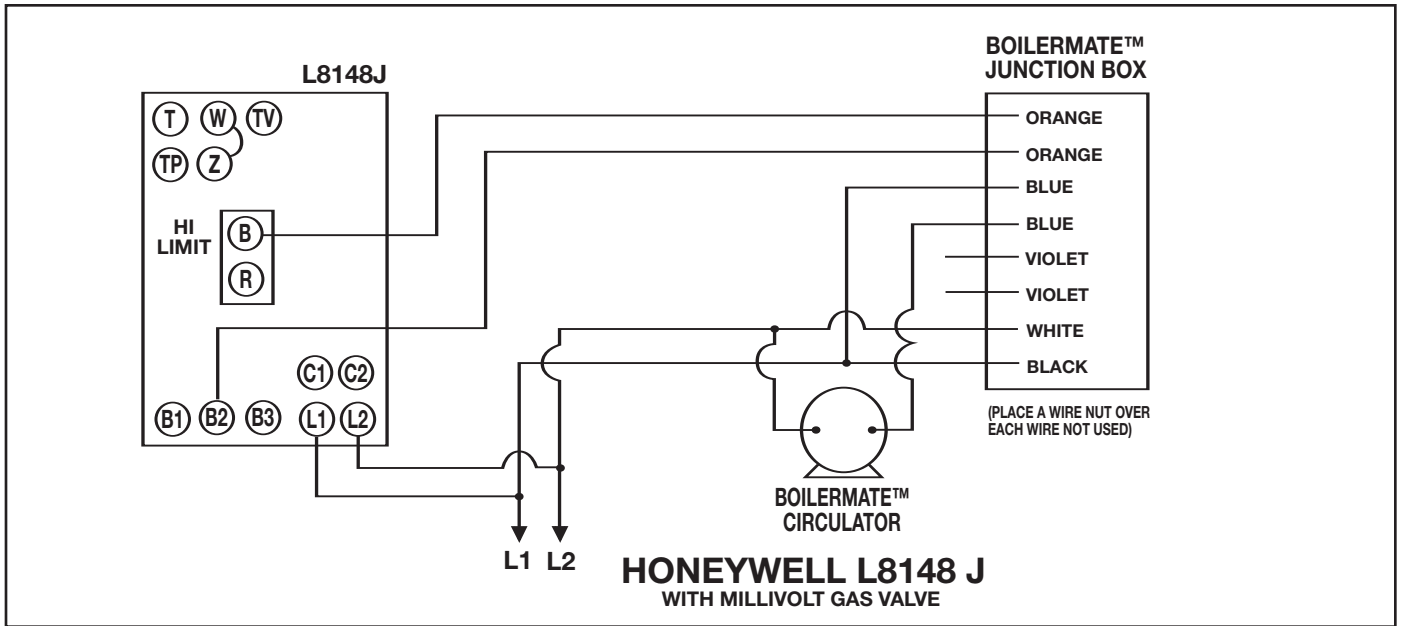

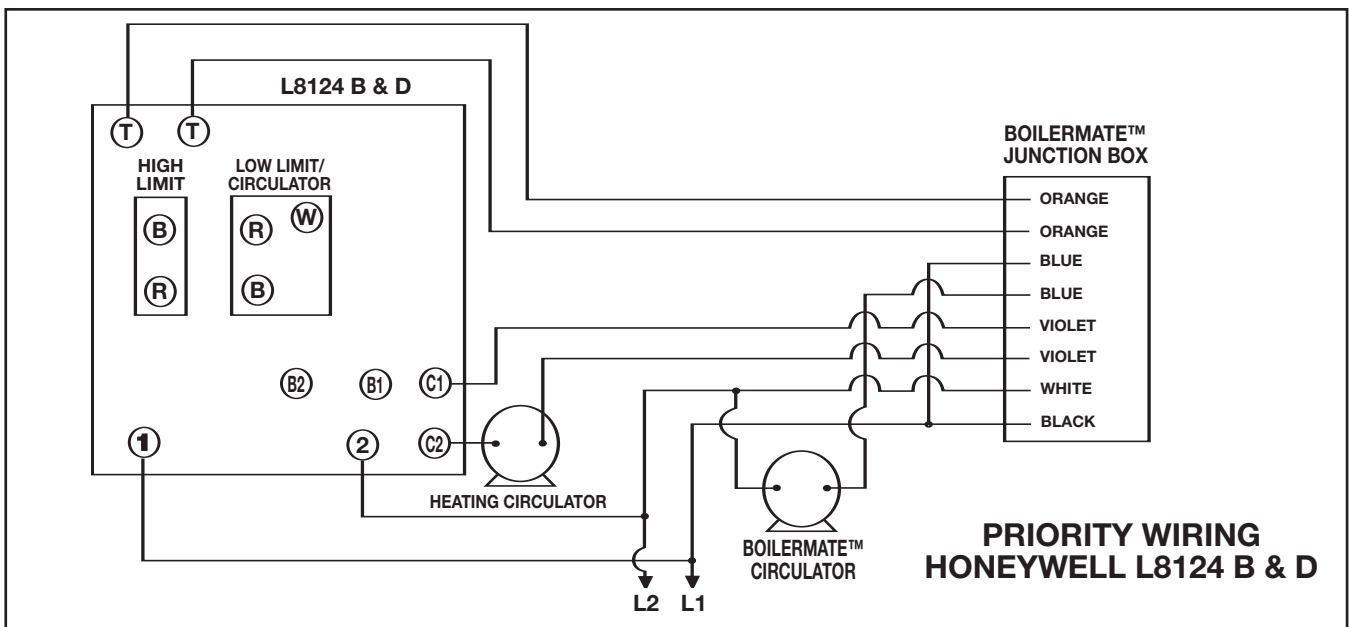
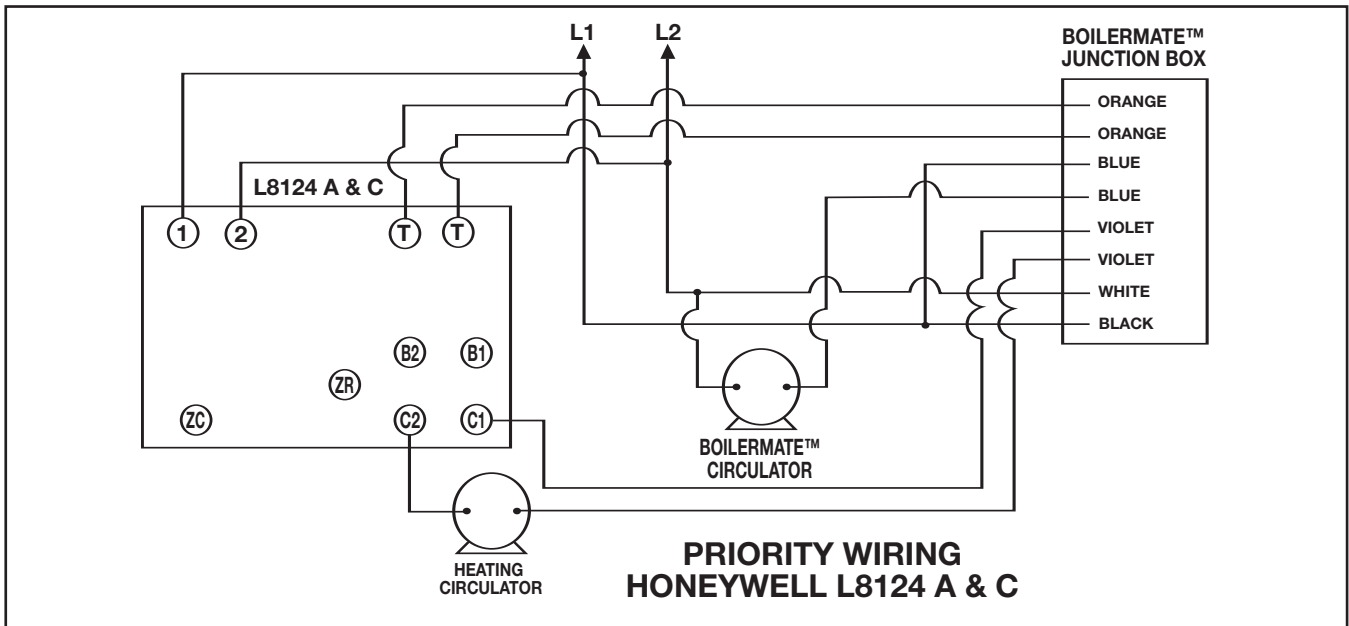
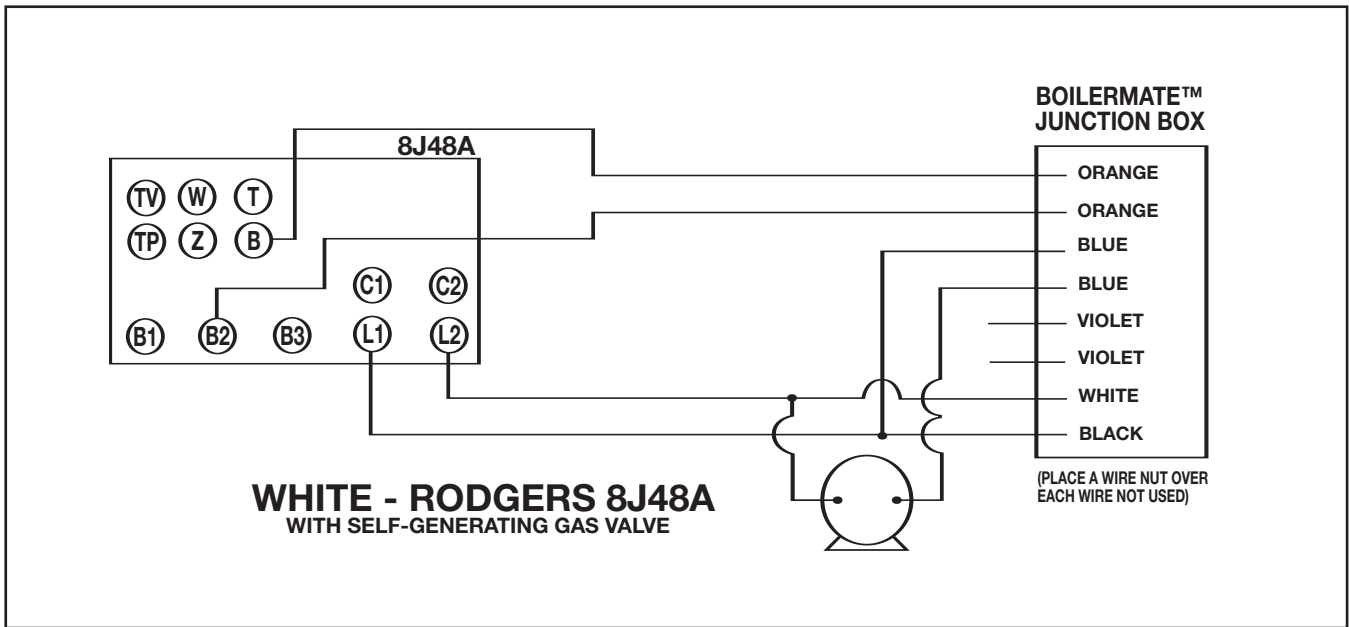

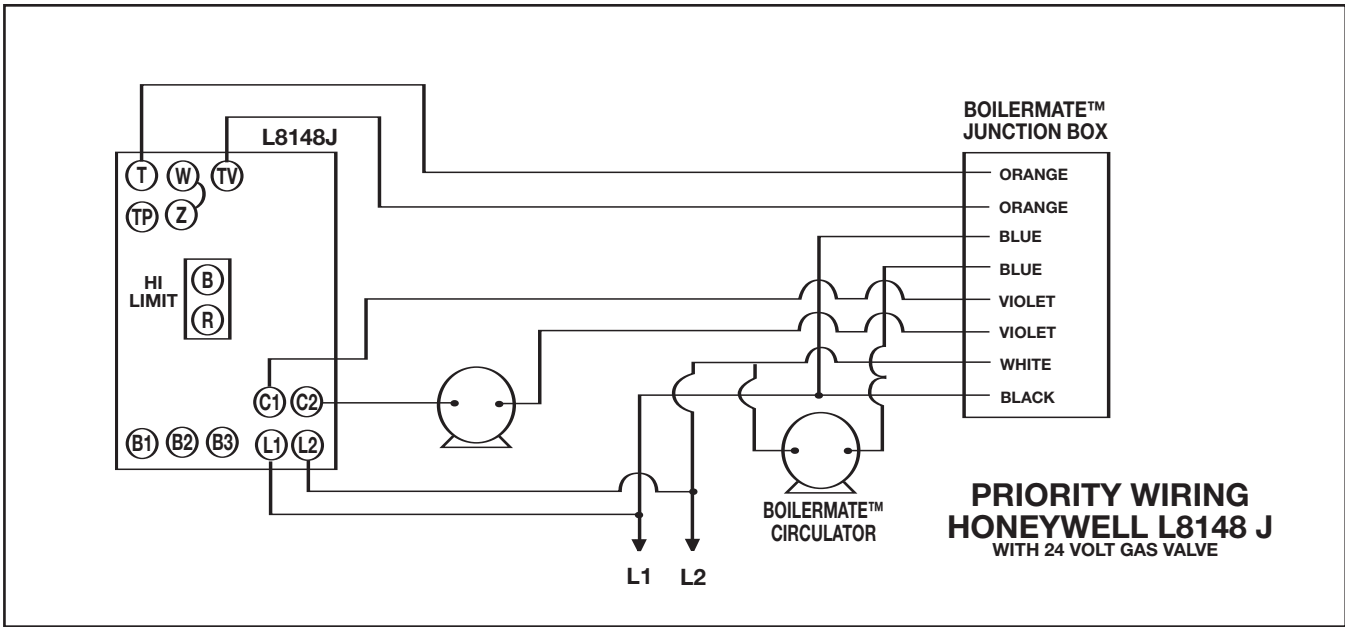
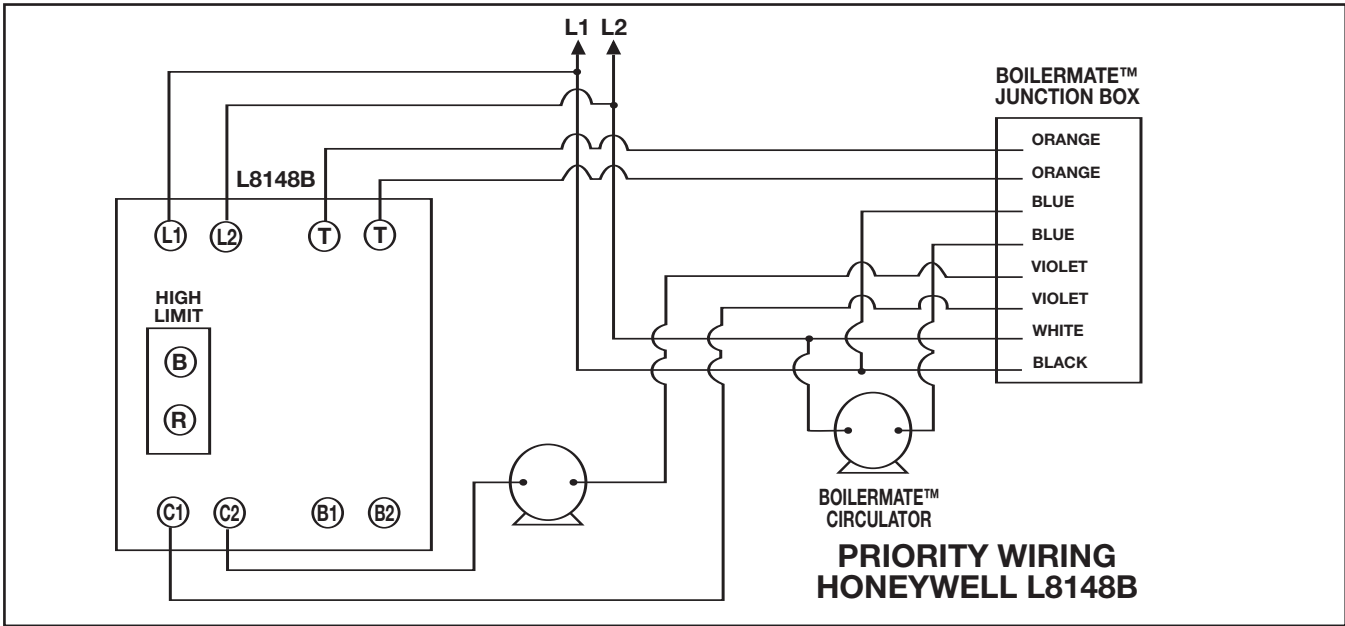
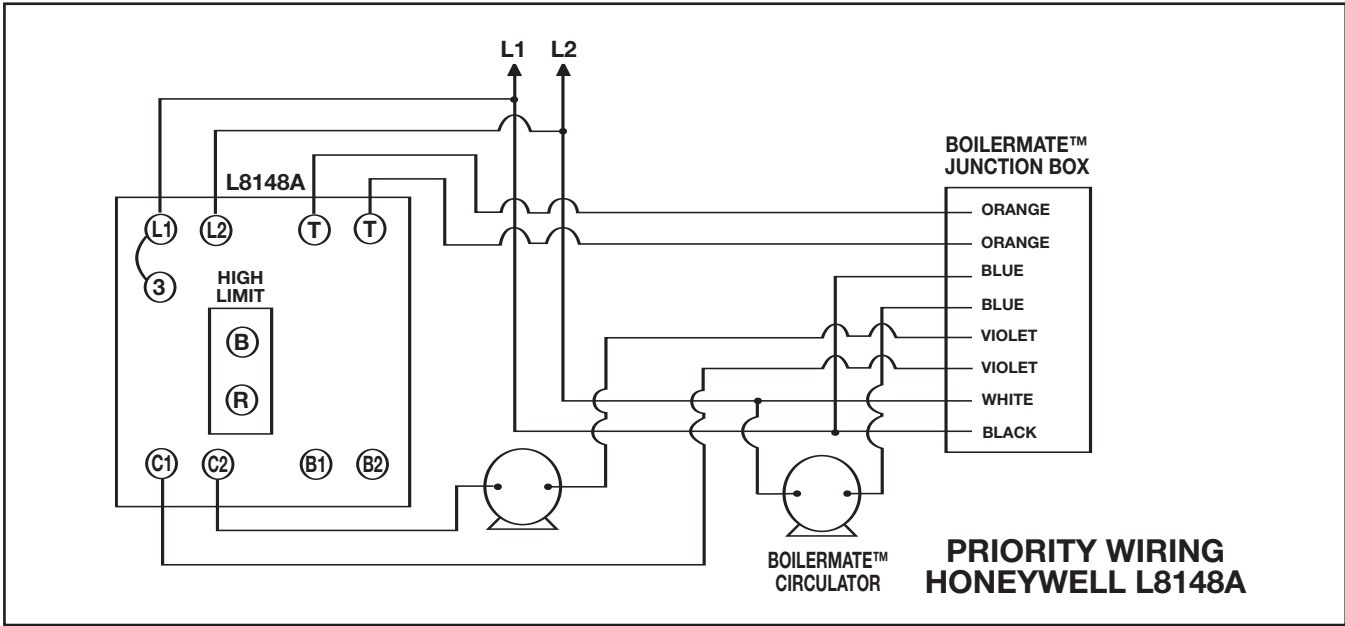

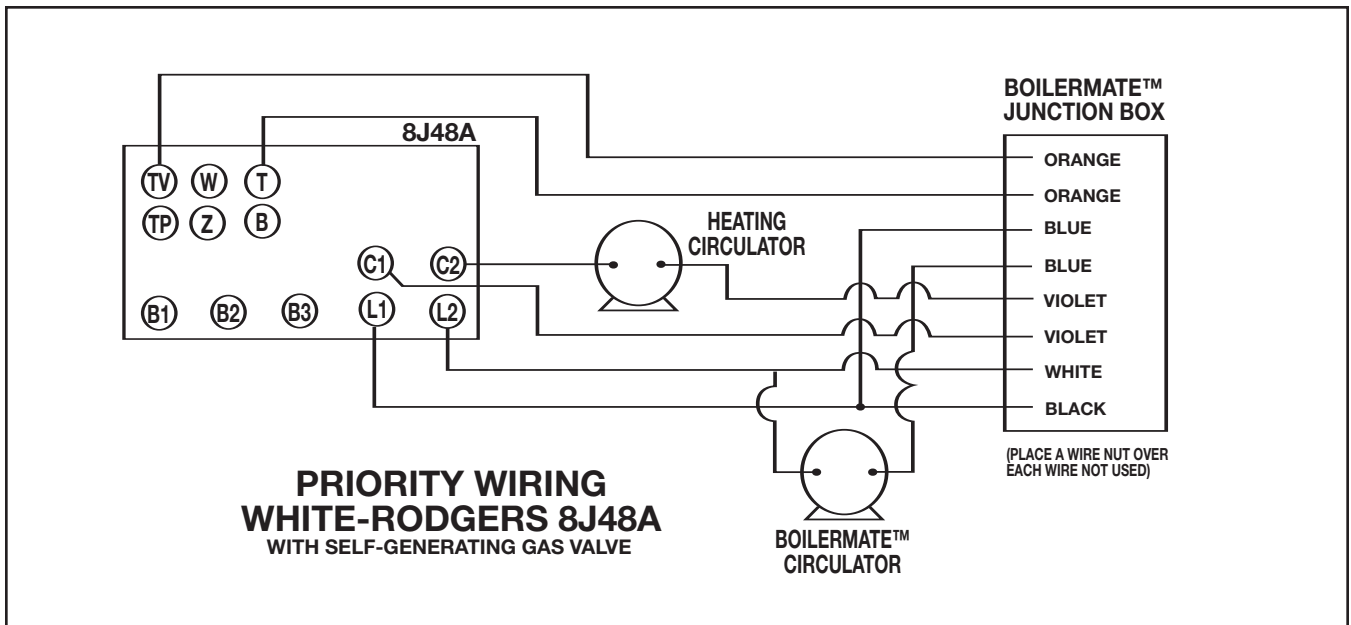
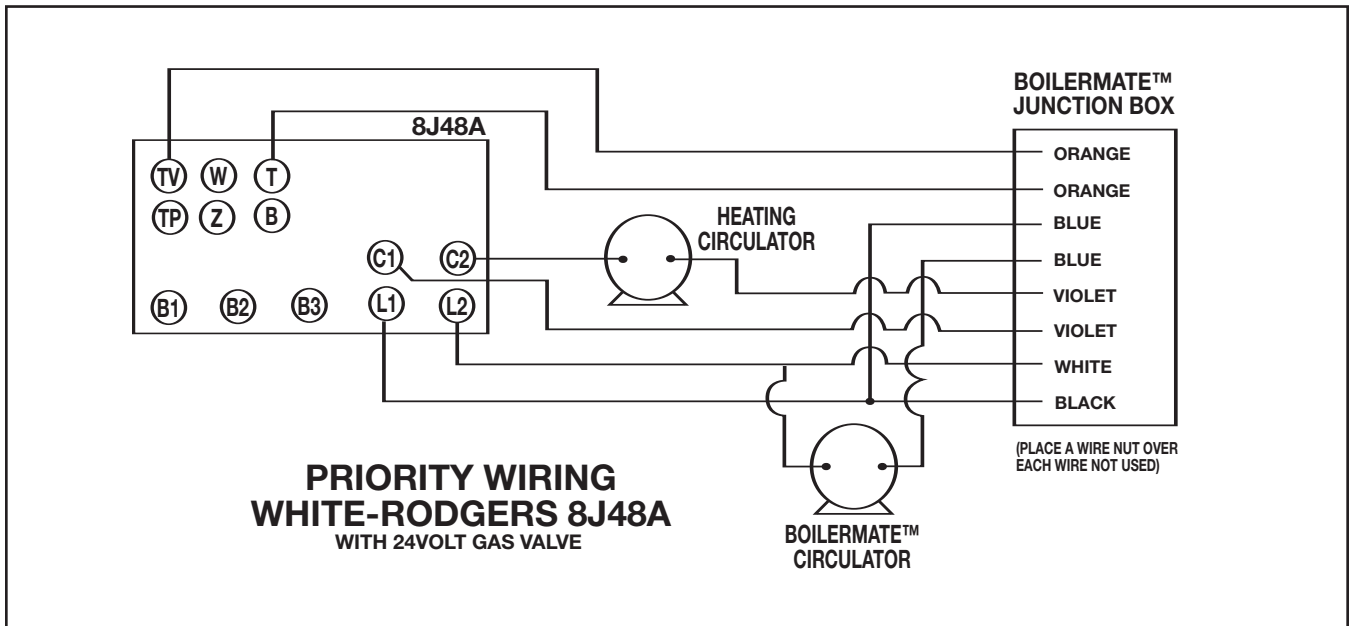
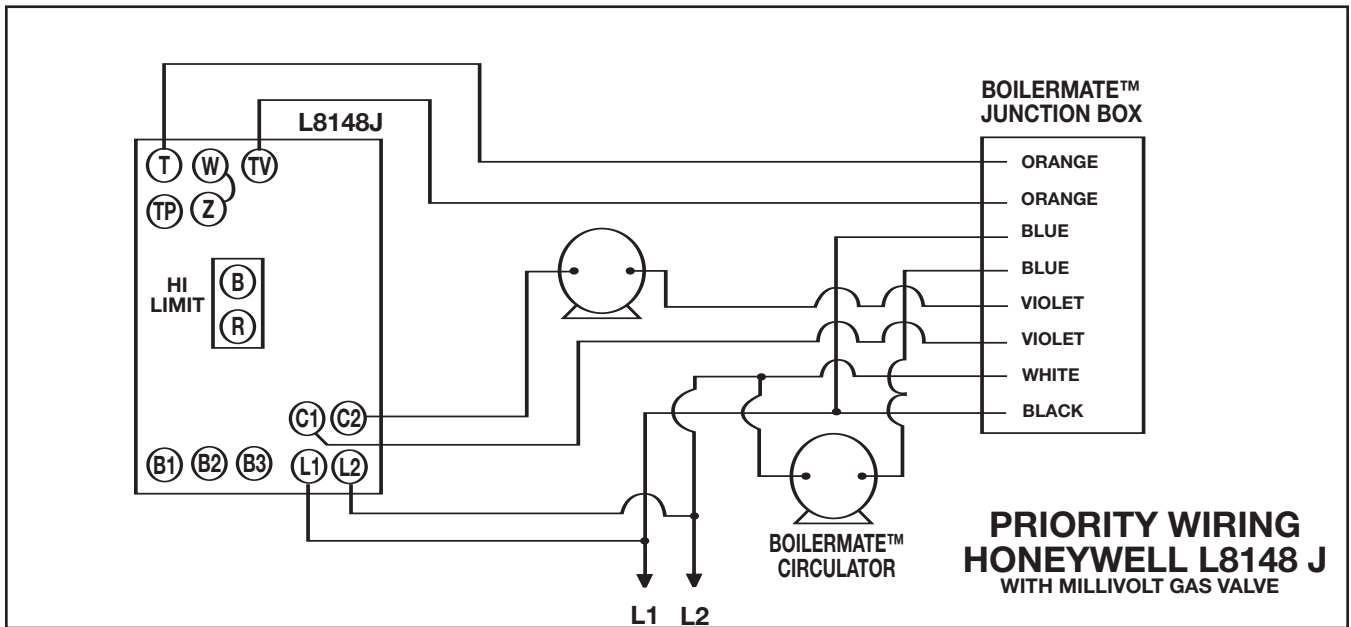

**Typical Multi-Zone Relay
Utilizing Post-Purge Feature**

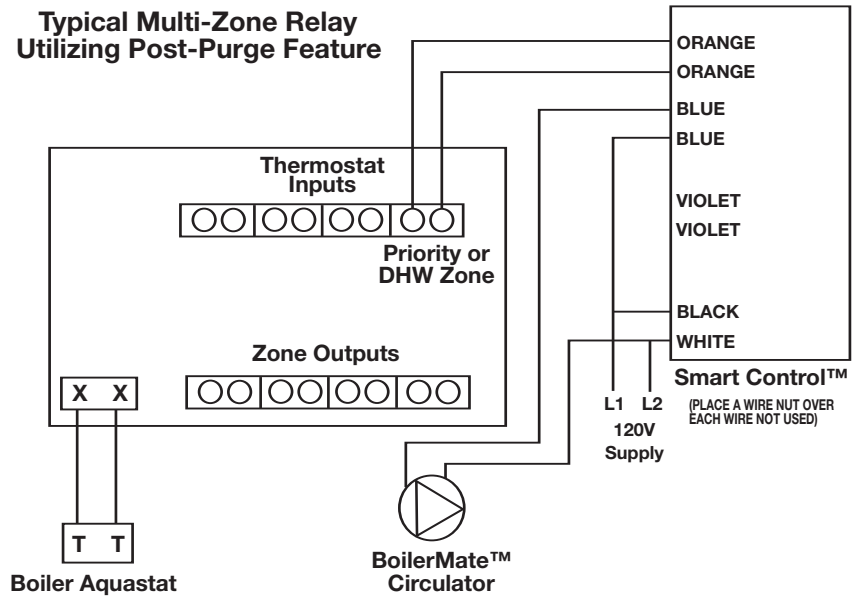

**Typical Multi-Zone Relay
24V without Post-Purge Feature**

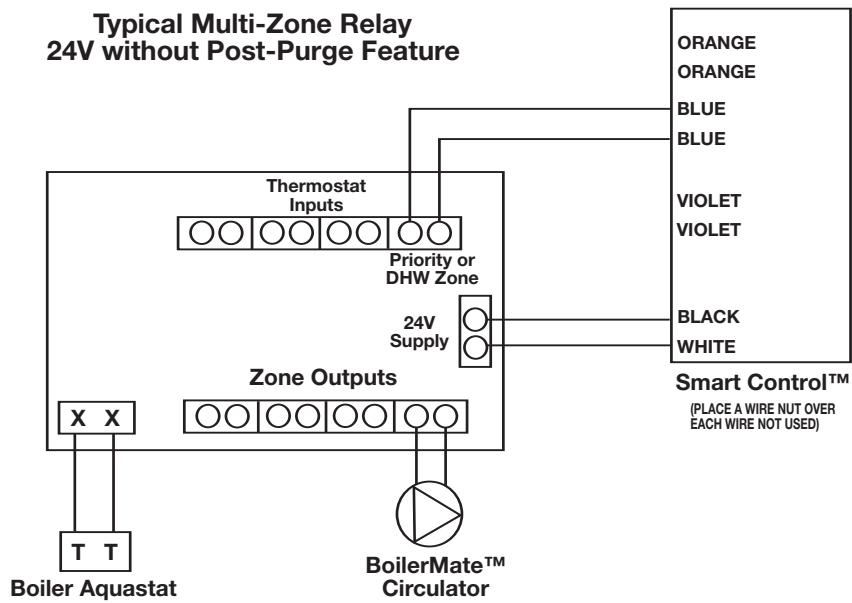

9. WIRING ALL DIAL CONTROL MODELS (EXCEPT RTR MODELS)

Dial Control models utilize a standard dry-contact aquastat with capillary temperature sensor. The dial control contains a make-and-break switch and is suitable for 24V or 120V, 25A Max.

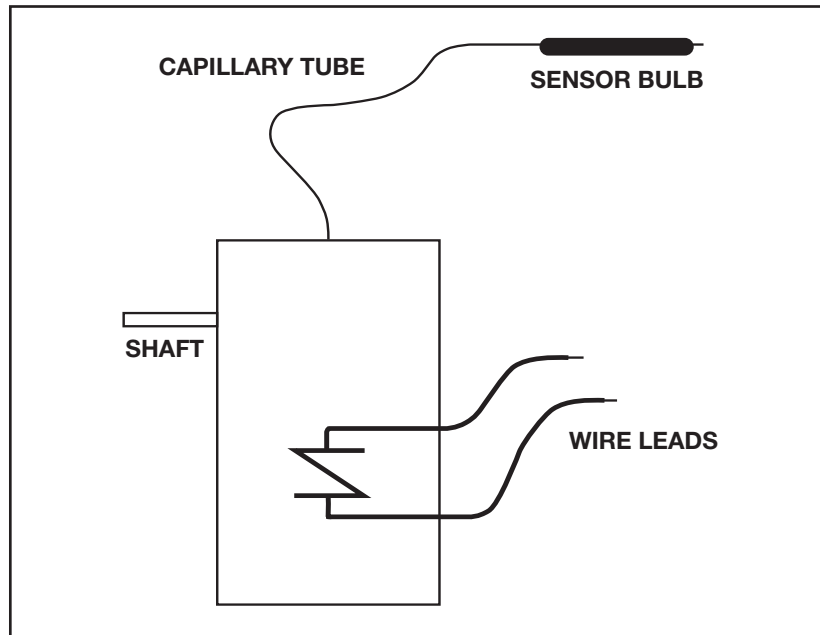

To wire Dial Control models, select the appropriate diagram from the following pages. If a suitable diagram is not available for your application, please contact AMTROL Tech Support at (401)535-1216. Always disconnect power before wiring the control. Ensure that the proper conduit and connectors are used per your local code. In lieu of local code, the National Electric Code should be followed.

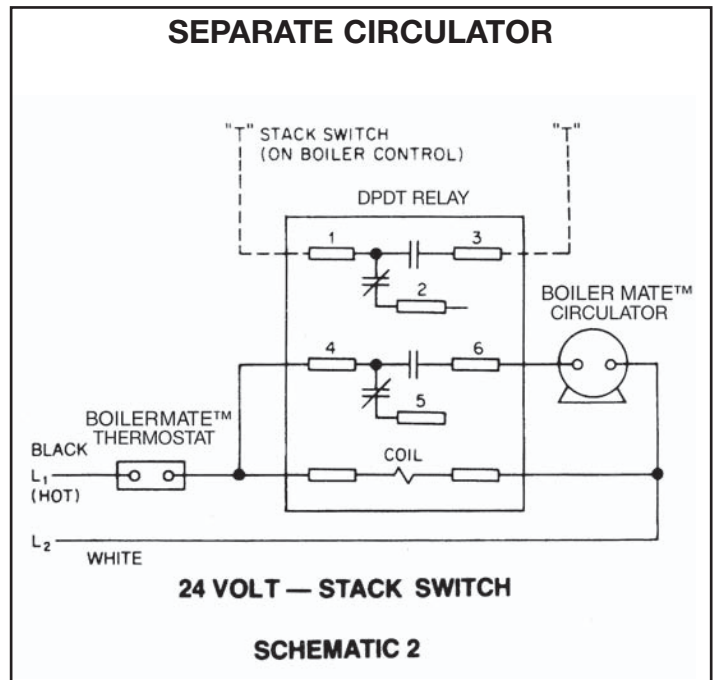
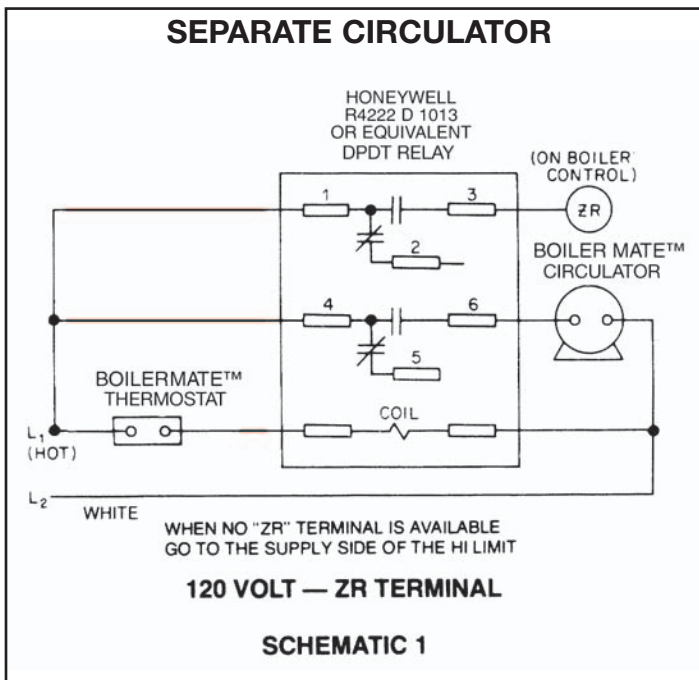

ZONE VALVES - SCHEMATIC 3

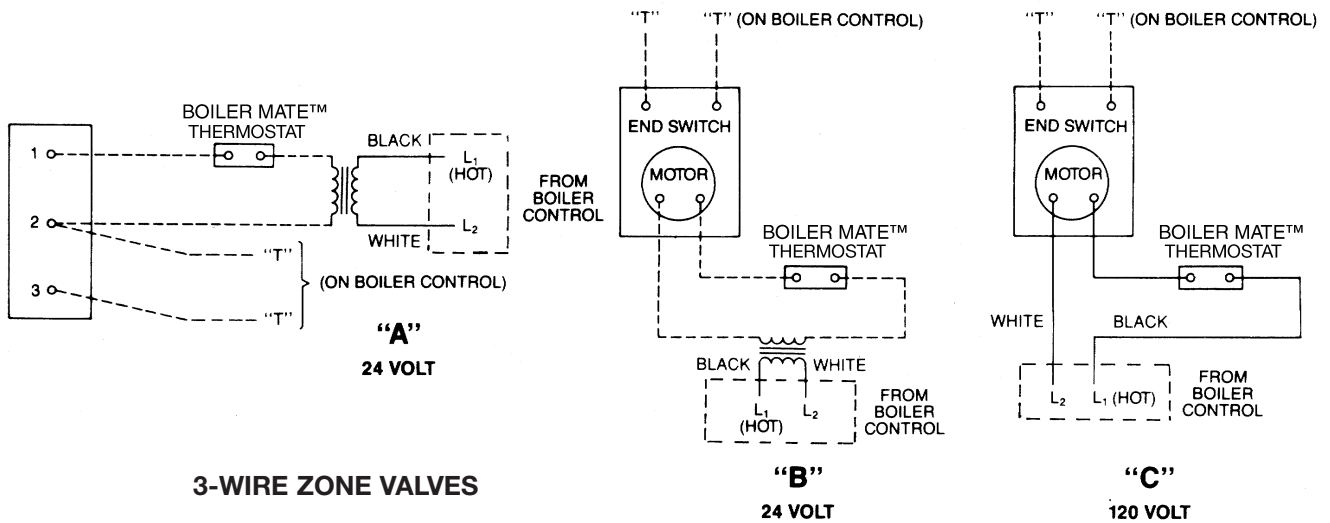

PRIORITY W/CIRCULATORS - SCHEMATIC 4

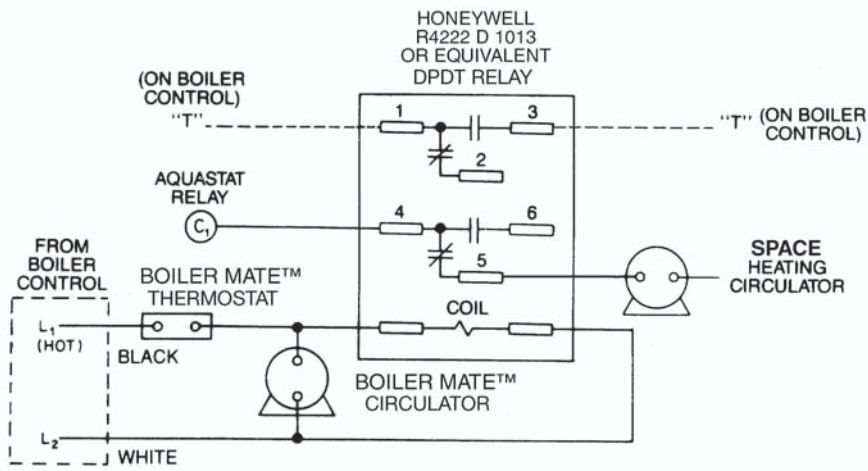

REMOVE WIRE FROM BOILER AQUASTAT TERMINAL AND EXTEND IT TO ATTACH TO TERMINAL #2 OF RELAY. ATTACH WIRE FROM TERMINAL #1 TO BOILER AQUASTAT TERMINAL C₁.

Typical Multi-Zone Relay

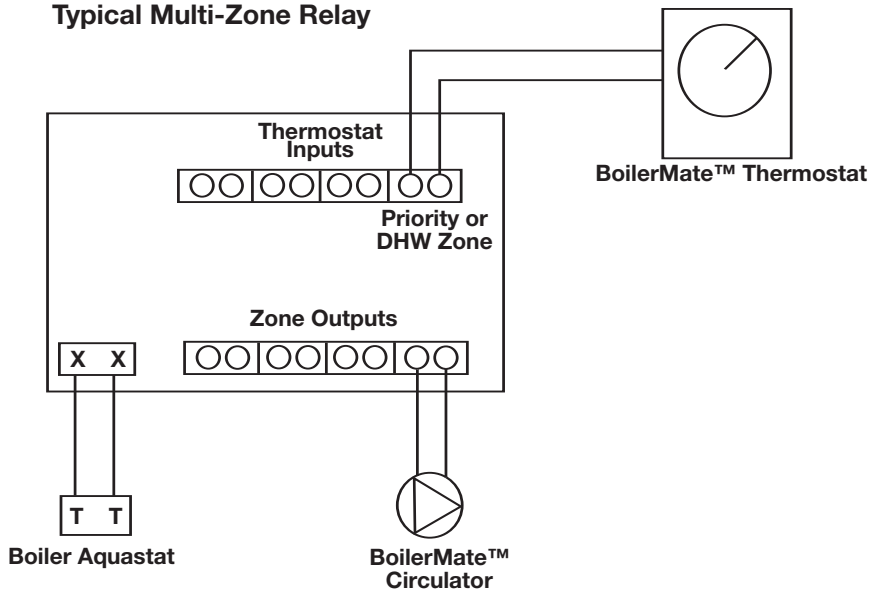

BOILER CONTROL - SCHEMATIC 5

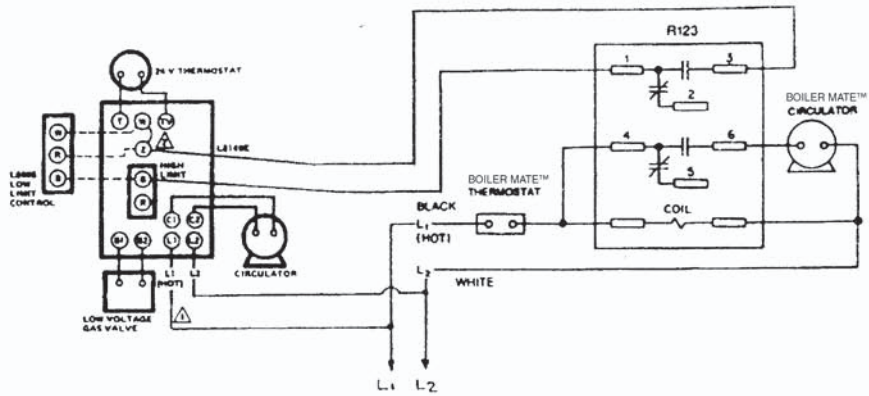

- ⚠ POWER SUPPLY PROVIDE DISCONNECT MEANS AND OVERLOAD PROTECTION AS REQUIRED
- ⚠ REMOVE JUMPER WHEN ADDING L6006 LOW LIMIT CONTROLLER TO SYSTEM
- ⚠ AT THE OPTION OF BOILER MANUFACTURER—NOT REQUIRED FOR HOT WATER MAKER OPERATION

HONEYWELL L8148E

10. WIRING ALL READY-TO-RUN (RTR) MODELS

Ready-To-Run models include a circulator with built-in priority zoning relay. The aquastat is pre-wired and controls the circulator. Line voltage must be supplied and a signal wire must be run to fire the boiler.

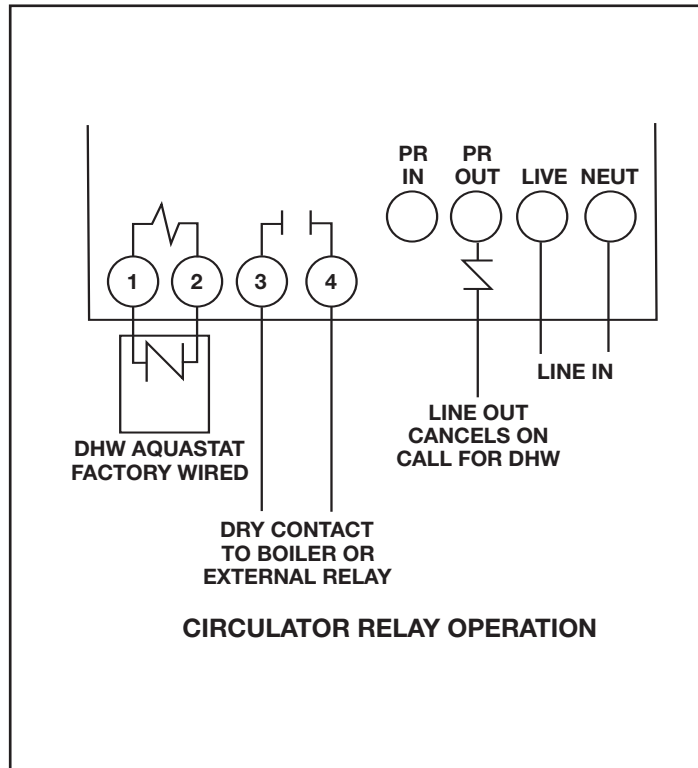

To wire RTR models, select the appropriate diagram from the following pages. If a suitable diagram is not available for your application, please contact AMTROL Tech Support at **(401)535-1216**. Always disconnect power before wiring the unit. Ensure that the proper conduit and connections are used per your local code. In lieu of local code, the National Electric Code should be followed.

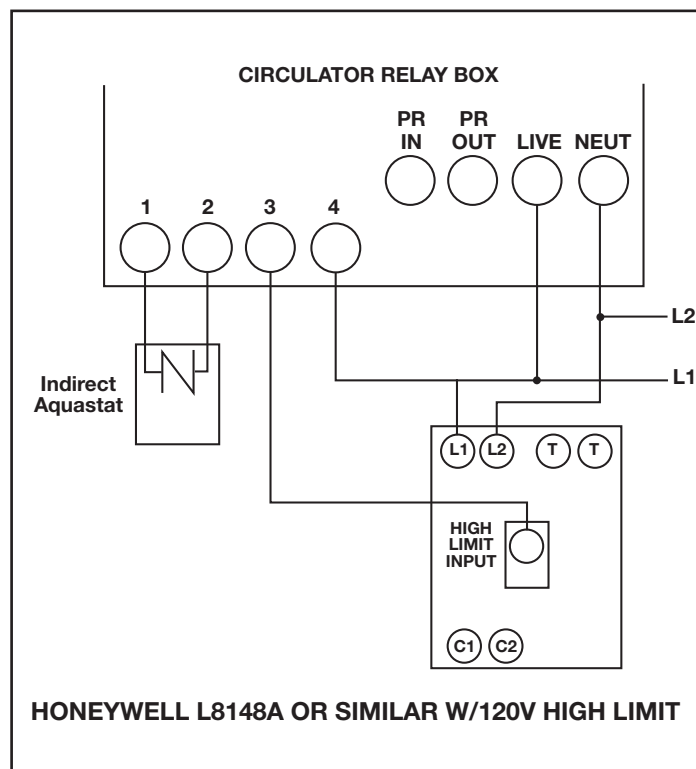

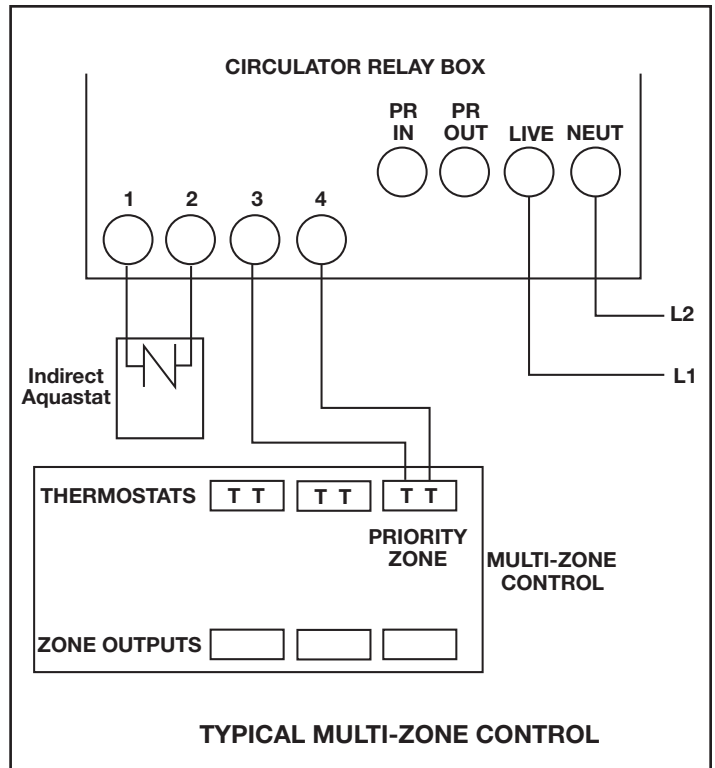
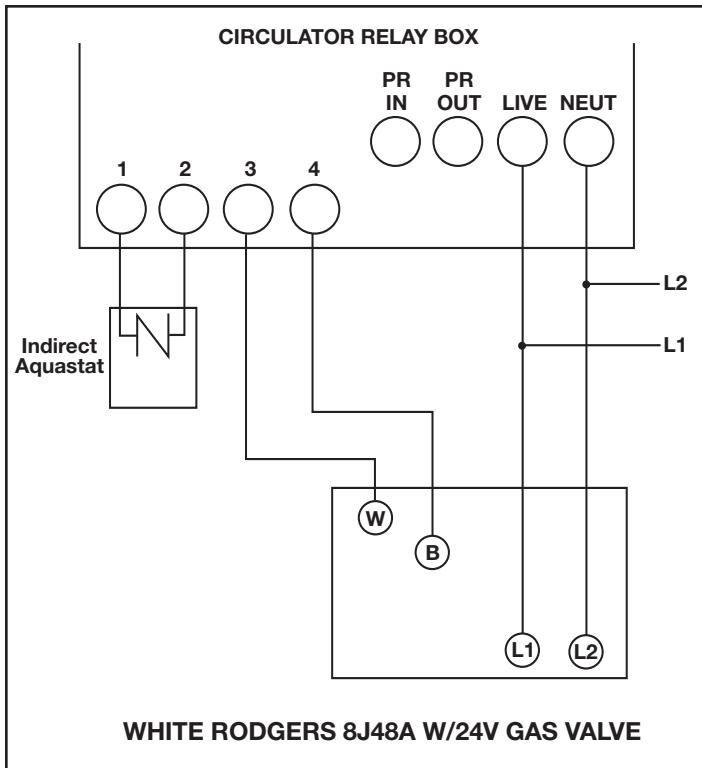
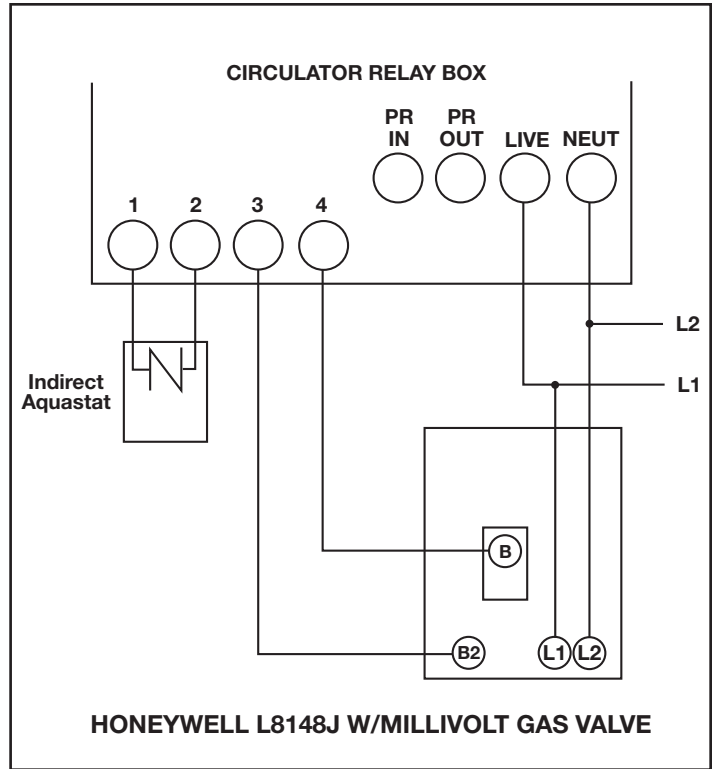
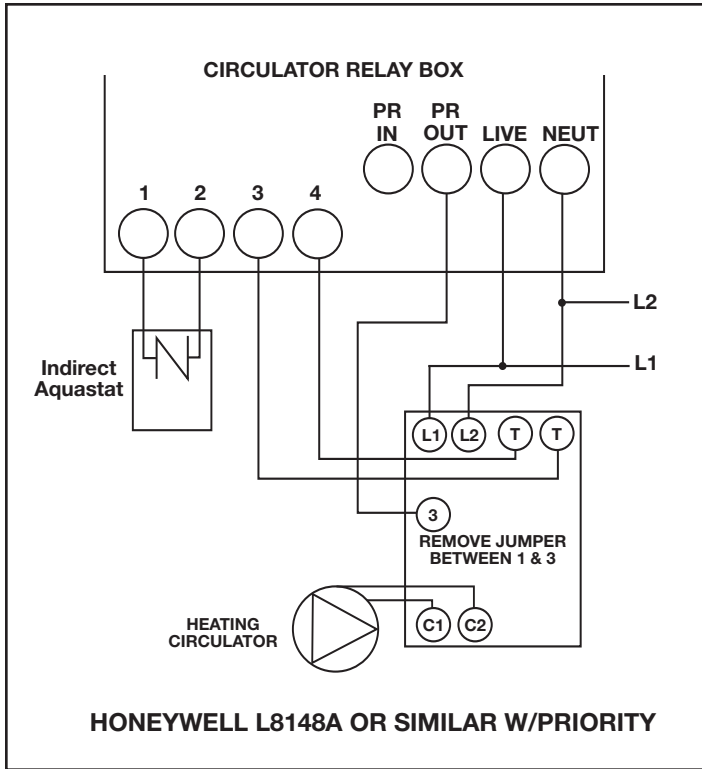

11. STARTUP PROCEDURE FOR ALL MODELS

- 1. PURGE HEAT EXCHANGER:** The heat exchanger should be free of large air pockets to allow the circulator to operate properly. Using the diagram below as a guide, isolate the boiler return line and flush the loop until large air pockets are purged. After this, the air elimination equipment will collect smaller air bubbles to maximize efficiency.
- 2. FILL TANK:** Open the hot water fixture furthest from the heater. Open the cold water supply and allow the water to run until air stops emerging. Until all air is purged from the hot water system, air pockets may appear at any hot water fixture. This is considered normal and will clear as hot water is used.
- 3. START HEATER:** Turn power on to the unit. Smart Control™ models come pre-set at 120°F for safety. Dial

units should have the knob rotated to the 120°F mark. The circulator and boiler should start momentarily. If not, check wiring and consult the troubleshooting section in this manual.

- 4. CHECK OPERATION:** The BoilerMate™ will begin to heat. Depending upon the size of the BoilerMate, output of the boiler and the space heating load, the unit should typically reach set temperature within 15 to 60 minutes. If heating does not occur, consult the troubleshooting section in this manual. Note: Large heaters coupled with small boilers may exceed this time period upon initial startup.
- 5. SET TEMPERATURE:** The BoilerMate™ control should be set to the minimum temperature consistent with the user's needs. This maximizes efficiency and reduces scald potential.

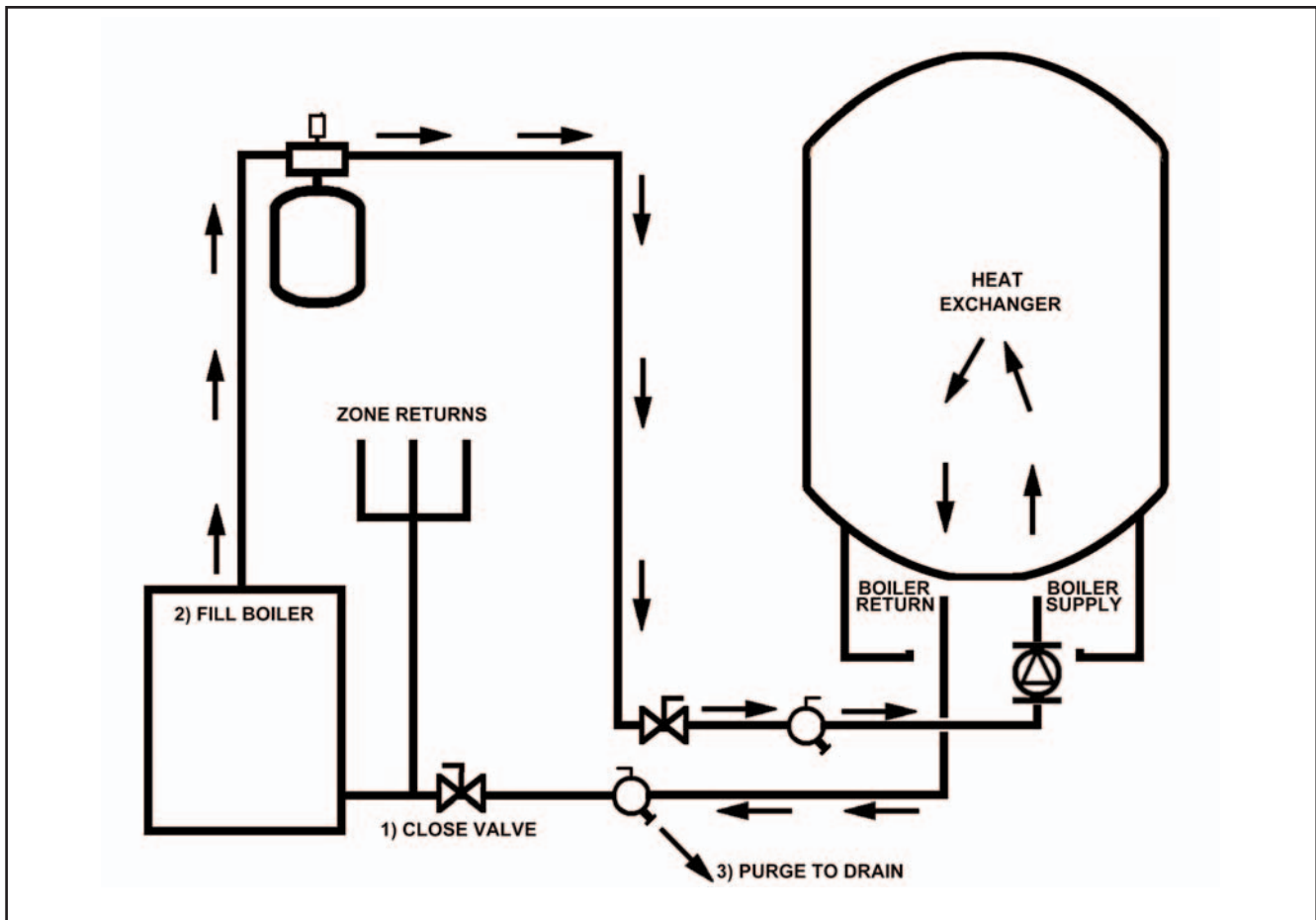

12. SETTING THE SMART CONTROL™

The Smart Control™ incorporates multiple features that increase hot water performance and efficiency. All settings are accessed via the MODE button. To change any setting, simply tap the MODE button to cycle through the settings as outlined below.



The Smart Control™ comes preset for 120°F water temperature and a volume of 41 gallons. To change any of the settings, refer to the instructions below:

- When power is applied to the unit, the display will show **[-00]** for 15 seconds. After the minus sign disappears, the boiler and circulator will activate.
- Depressing the MODE switch once will display **[41P]** then 41. This is the tank volume. To change the volume when the 41 is displayed, push and hold the ▲ or ▼ button for (2) two seconds, then tap either button to choose the proper tank size (26, 41, 60, 80 or 120).
- Depressing the MODE switch twice will display **[120P]** then 120°F. This is the water temperature set point. To change the set point when the display reads 120°F, push and hold the ▲ or ▼ button for (2) two seconds to raise or lower the temperature. The temperature can be set between 90° and 150°F. To shut the unit down, scrolling below 90°F will display 0°F, then in seconds, **[0FF]**. This is beneficial if the heater will not be used for an extended period of time.

⚠ WARNING Temperature settings above 120°F can create a scald hazard.

- Depressing the MODE switch three times will display **[10F]** then 10°F. This is the differential set point and determines how many degrees the water temperature is allowed to drop before the water heater activates. To change between the available 10°F and 5°F settings, press and hold the ▼ button for (2) two seconds then tap the ▲ or ▼ buttons to select. **NOTE:** If differential is set to 5°F, the post purge feature is not available and is automatically set to 0 and post purge display will not function.
- Depressing the MODE switch four times will display **[PRE]** then 0. This is the preheat setting and will determine how long the boiler runs before the circulator starts. Large capacity boilers generally take longer to heat from a cold start. In such cases, preheating prevents cold boiler water from flowing through the coil. To change, push and hold the ▲ button for (2) two seconds, then press ▲ or ▼ to cycle through the available 0, 1, 3, & 5 minute settings.

- Depressing the MODE switch five times will display **[PO5]** then 0. This is the post purge setting in degrees and determines at what temperature prior to the BoilerMate™ setpoint, in which the boiler will be shut down, while the circulator continues to run. This is useful in removing excess heat from the boiler when it shuts down. To change, push and hold the ▲ button for (2) two seconds then push the ▲ or ▼ to cycle through the available 0, 4, & 8 degrees settings. **NOTE:** If differential is set to 5°F, the post purge feature is not available and is automatically set to 0 and post purge display will not function.
- Depressing the MODE switch six times will display **[BTU]** and a number. This is the BTU transfer rate in thousands. This is a diagnostic readout and cannot be changed.
- **NOTE:** Any changes made to the above settings will take effect after 15 seconds. This will be acknowledged by a display of **[EEP]**. The changes made after this display will be the new control settings even in the event of a power outage.
- The current internal tank temperature can be displayed by first pushing ▲ and ▼ buttons simultaneously. Then, while still holding ▲ and ▼ buttons, push the mode button. Internal temp will then be displayed. This is the domestic water temperature in °F.
- There are two error codes that will be displayed if abnormal operation occurs. This first is **[Er1]** and indicates an unplugged or damaged thermistor (temperature sensor) wire. Check and replace as necessary. The second is **[Er2]** and appears when the stored water temperature exceeds 155°F. Contact your service person to correct the problem.
- **NOTE:** When using the BoilerMate™ on a zone valve application, the post purge feature will not function.

13. TROUBLESHOOTING

PROBLEM	SOLUTION	SOLUTION
No hot water	<ol style="list-style-type: none"> 1. No power to unit 2. Air in heat exchanger loop 3. Faulty circulator or zone valve 4. Faulty BoilerMate™ thermostat 5. Faulty Smart Control™ 6. Boiler inoperable 	<ol style="list-style-type: none"> 1. Check circuit breaker, boiler emergency switch and boiler reset switch 2. Purge air. Ensure circulator is on Boiler Supply. Check air vents 3. Check circulator and zone valve. Repair or replace if necessary 4. Check continuity while rotating knob. Circuit should open and close. 5. If blank, check power. Check continuity across two orange and two blue leads while green light is on. If none, open control and replace fuses or replace control. 6. Check boiler system. Boiler must operate to generate hot water
Insufficient hot water	<ol style="list-style-type: none"> 1. Demand exceeds capacity 2. Temperature too low 3. Boiler lacks sufficient output 4. Fouled heat exchanger 5. Insufficient heat exchanger flow 	<ol style="list-style-type: none"> 1. Check sizing based on household size and boiler output 2. Increase temperature setpoint 3. Wire for priority. If problem persists add storage or increase tank size. 4. Check Boiler Supply/Boiler Return during cold startup. If difference is less than 20°F, clean heat exchanger as outlined below. Install water treatment equipment to prevent recurrence. 5. Check for undersized or faulty circulator, stuck or undersized zone valve. Ensure all shutoff valves are open. Check for stuck flow check valve. Purge boiler loop to remove air.
Water too hot and/or ER2 message on Smart Control™	<ol style="list-style-type: none"> 1. Improper plumbing 2. Temperature set too high 3. Temperature sensor not fully inserted 4. Stuck zone valve 5. Flow check valve stuck open 	<ol style="list-style-type: none"> 1. If Boiler Return is plumbed to the suction-side of a heating circulator, overheating will occur when the home's heat is on. Fix plumbing. 2. Reduce temperature setpoint 3. Re-insert thermistor wire or temperature sensor. 4. Repair or replace 5. Clean, repair or replace
Noise from BoilerMate™	<ol style="list-style-type: none"> 1. Air in boiler loop 2. Faulty circulator pump 3. Thermal expansion 4. Normal noise during initial fill 	<ol style="list-style-type: none"> 1. Purge boiler loop. Check air elimination equipment. 2. Repair or replace pump 3. Ensure the proper Therm-X-Trol® or equivalent thermal expansion tank is installed and adjusted properly 4. When first pressurized, a creaking or hissing sound is normal. After pressurizing, the noise should stop. Always check for leaks.
Relief valve dripping or opening	<ol style="list-style-type: none"> 1. No thermal expansion tank 2. Thermal expansion tank set improperly 3. City pressure too high 4. System over temperature 5. Faulty relief valve 	<ol style="list-style-type: none"> 1. Install the proper Therm-X-Trol® or equivalent thermal expansion tank 2. Ensure precharge air pressure matches static water pressure 3. Install a Pressure Reducing Valve (PRV) if city pressure is over 80psi 4. Determine cause of over temperature condition and correct problem 5. Replace relief valve
ER1 message on Smart Control™	<ol style="list-style-type: none"> 1. Temperature sensor unplugged 2. Temperature sensor cut or faulty 3. Water in therm-well 	<ol style="list-style-type: none"> 1. Sensor is unplugged from factory. Plug into Smart Control™ receptacle 2. Replace sensor wire (thermistor) 3. Replace therm-well
Discolored water at faucet	<ol style="list-style-type: none"> 1. Poor water quality 2. Sediment or suspended particles 	<ol style="list-style-type: none"> 1. Have water tested for contaminants. Typical problems are: Blue/green color = copper discoloration due to low pH Black staining/sulfur odor = hydrogen sulfide White deposits = hard water Red staining = high iron levels 2. Install sediment filter, purge unit more often to avoid future problems
Boiler will not operate when calling for hot water	<ol style="list-style-type: none"> 1. Improper or loose wiring 2. Boiler high limit has been reached 3. Fuse blown in Smart Control™ 4. Post Purge (POS) set too high 5. Problem with boiler system 	<ol style="list-style-type: none"> 1. Check connections against wiring diagrams in this manual 2. Boiler will periodically cycle on and off during operation 3. Remove 4 screws inside the Smart Control™ wiring box. Replace glass fuse(s) with those of the same rating 4. Post Purge shuts the boiler off prior to reaching domestic setpoint. If set too high, the boiler may not have enough energy to raise the water temperature to setpoint. Reduce POS or set to 0 if the problem persists 5. Have boiler diagnosed for proper operation
Circulator or zone valve will not operate when calling for hot water	<ol style="list-style-type: none"> 1. Improper or loose wiring 2. Pre Purge (PRE) set too high 3. Fuse blown in Smart Control™ 4. Faulty circulator pump 	<ol style="list-style-type: none"> 1. Check connections against wiring diagrams in this manual 2. PRE setting delays circulator startup. This is not normally needed in residential applications. Reduce PRE or set to 0 if problem persists 3. Remove 4 screws inside the Smart Control™ wiring box. Replace glass fuse(s) with those of the amp same rating 4. Repair or replace pump

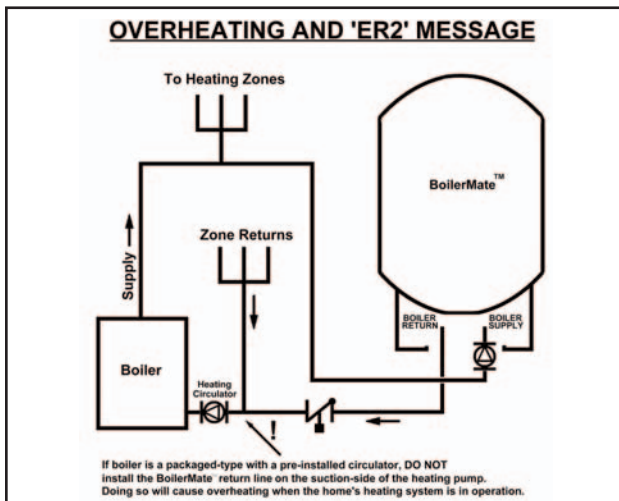

WATER QUALITY AND YOUR BOILERMATE™

Water condition can adversely affect the performance and longevity of your water heater. It also plays an important role in the taste and appearance of your water. AMTROL offers a FREE water analysis as a service to our customers.

To obtain a water test, call **(800)462-3790** or **(401)535-1216**. We will send a sample bottle to be filled. After returning the sample, you will receive a water report and recommendations on improving your water condition.

14. REPLACEMENT PARTS

	WH-7, 41 and 9 Series	TD-7 Series	TD-7 RTR	TD-80 Series	WHS 60 & 80 Residential	WHS 120 Residential	WHS 60 & 80 Commercial	WHS 120 Commercial
Single Wall Heat Exchanger w/Gasket and Nuts	2700-5000	2700-5005	2700-5007	2700-5008	2775-82	2775-81	2700-5001	2700-5001
Double Wall Heat Exchanger w/Gasket & Nuts	2700-5002	2700-5006	N/A	N/A	2775-83	2775-83	2775-84	2775-84
Commercial Heat Exchanger w/Gasket & Nuts	2700-5001	N/A	N/A	N/A	N/A	N/A	See Above	See Above
Top Outlet Tee w/O-Ring	2700-635	N/A	N/A	N/A	N/A	N/A	N/A	N/A
Flange Gasket: Bottom & Top	2704-403	2704-403	2704-403	2704-403	2704-403	2704-403	2704-403	2704-403
Thermo-Well Assembly	2700-924	2700-924(exc DW)	2700-924	2700-1167	2700-924	2700-924	2700-924	2700-924
Top Outlet O-Ring or Bottom Drain O-Ring	2500-178	2500-178	2500-178	2500-178	N/A	N/A	N/A	N/A
Smart Control™	2704A233	2704A233	2704A233	2704A233	2704A233	2704A233	N/A	N/A
Sensor (thermistor) wire	2704-259	2704-259	2704-259	2704-259	2704-259	2704-259	N/A	N/A
Dial Aquastat (residential)	2704-093	2704-093	2704-093	2704-093	2704-093	2704-093	N/A	N/A
Dial Aquastat (commercial)	N/A	N/A	N/A	N/A	2775-454	2775-454	2775-454	2775-454
Conversion Kit: Dial Aquastat to Smart Control™	2704-227	2704-227	N/A	2704-227	2775-389	2775-389	2775-389	2775-389
Conversion Kit: Smart Control™ to Dial Aquastat	2704-392	2704-392	N/A	2704-392	2775-455	2775-455	2775-455 plus 2775-454	2775-455 plus 2775-454
Circulator Pump	245-58	245-58	245-62	245-58	245-58	245-58	N/A	N/A

To obtain replacement parts, contact the installer or place of purchase. Technical support is available by calling AMTROL at (401) 535-1216.

15. GENERAL SAFETY INFORMATION

⚠ DANGER SCALDING HAZARD. If the water temperature is over 120°F, household members can suffer serious or fatal scalding and painful and permanent injury. • The Consumer Products Safety Commission recommends an initial setting of 120°F, but notes a slower response time of infants, aged, disabled and other persons increases the scalding hazard and may require lower settings. • Always check the water temperature before use, including washing, bathing or showering. • Temperature limiting valves are available from your plumbing supplier. A check valve must be installed in the boiler return line to prevent gravity flow through the heat exchanger. This can cause overheating and result in serious or fatal scalding.

⚠ DANGER SCALDING HAZARD. If the thermostat is not working properly or if this product is not installed in accordance with the manual, water temperature can reach excessive levels that may cause serious or fatal scalding. After installation and any servicing of the unit, verify that the thermostat is working and firmly inserted in the thermostat well by following the thermostat testing instructions in the manual.

⚠ WARNING Failure to use the correct replacement parts may make your product unsafe.

⚠ WARNING CALIFORNIA PROPOSITION 65 WARNING! **WARNING:** This product contains a chemical known by the State of California to cause cancer and birth defects or other reproductive harm. (California Installer/Contractor - California law requires that this notice be given to consumer/end user of this product.) **For more information: www.amtrol.com/prop65**

⚠ WARNING In limited circumstances, space heating can be lost in the home with unit utilizing priority mode. Any demand for space heating is postponed until the Boiler Mate™ has reached its set temperature. This delay in supplying the space heating zones is usually not noticed by the inhabitants of the living spaces. However, in the event of certain malfunctions such as circulator or thermostat failure, space heating could be delayed indefinitely. If undetected and uncorrected, freezing damage to piping could result.

⚠ CAUTION If a steel hydropneumatic tank is in place, AMTROL® recommends replacing it with a properly sized EXTROL® expansion tank. Otherwise, significant heat transfer problems can occur by causing air to be trapped in the heat exchanger. If the boiler system has an EXTROL® or Radiant EXTROL™ expansion tank and the boiler temperatures are being changed, resize the EXTROL® or Radiant EXTROL™ expansion tank.

⚠ WARNING If installing on city water supply a properly sized THERM-X-TROL® is required with the BoilerMate™ and should be installed as set forth in the THERM-X-TROL® product installation manual. Contact your water supplier or local plumbing inspector for additional information.

⚠ DANGER Prevent pressure build-up in any existing internal tankless coil. Do not plug incoming or outgoing tappings in the internal tankless coil plate. Leave the coil in the boiler and leave system connections open, to prevent pressure build-up.

⚠ DANGER **Electrocution hazard.** The BoilerMate™ must be electrically grounded. Electrical supply must come from the boiler

side of boiler's emergency shut-off switch in order to prevent unsafe boiler operation.

⚠ WARNING **Chlorine Aggressive Water:** The water quality can significantly influence the life of this Product. You should test for corrosive elements, acidity, total solids and other relevant contaminants, including chlorine and treat your water appropriately to insure satisfactory performance and prevent premature failure.

Note: Inspect for shipping damage and notify freight carrier or store where purchased immediately if damage present. To avoid risk of personal injury and property damage, if the product appears to be malfunctioning or shows signs of corrosion, call a qualified professional immediately. Current copies of the Product manual can be viewed at www.amtrol.com. Use proper safety equipment when installing.

⚠ DANGER **EXPLOSION HAZARD.** The pressure of the heat transfer medium must be limited to a maximum of 30 psig by an approved safety or relief valve on your boiler. The BoilerMate™ pressure must be limited to 150 psig maximum by the installation of a temperature and pressure relief valve (included). The relief tube must be plumbed to a suitable drain per code. No reducing coupling or other restriction may be placed in this line.

⚠ WARNING This Product, like most Products under pressure, may over time corrode, weaken and burst or explode, causing serious or fatal injury, leaking or flooding and/or property damage. To minimize risk, a licensed professional must install and periodically inspect and service the Product. A drip pan connected to an adequate drain must be installed if leaking or flooding could cause property damage. Do not locate in an area where leaking could cause property damage.

⚠ WARNING **EXPLOSION OR RUPTURE HAZARD.** A relief valve must be installed to prevent pressure in excess of local code requirement or maximum working pressure designated in the Product Manual, whichever is less. Do not expose Product to freezing temperatures or temperatures in excess of the maximum rated operating temperature.

⚠ DANGER If not installed by the boiler manufacturer, install a low water cut-off or pressure reducing valve on your boiler so that leaking will not result in a dry boiler which if the boiler continues to fire, will cause an explosion hazard.

⚠ DANGER This unit must be installed as a separate heating zone. Do not connect this unit to an existing heating zone or feed boiler water directly through the coil as dangerous over-heating will result.

⚠ CAUTION Do not drain this appliance before shutting off the supply valve and opening the relief valve or another downstream fixture, as it will damage this unit. A vacuum breaker should be installed to avoid damaging the liner. Damage to the unit and leakage can occur if a vacuum breaker is not installed.

⚠ WARNING **USE GLYCOL ONLY WITH DOUBLE-WALLED HEAT EXCHANGER MODELS.** Avoid risk of ingesting a toxic glycol fluid. The heat transfer medium should be water. If glycol must be used, it should only be used with double-walled heat exchangers and closely monitored for leakage.

